

Writing Your Thesis

(A Practical Guide for Students)

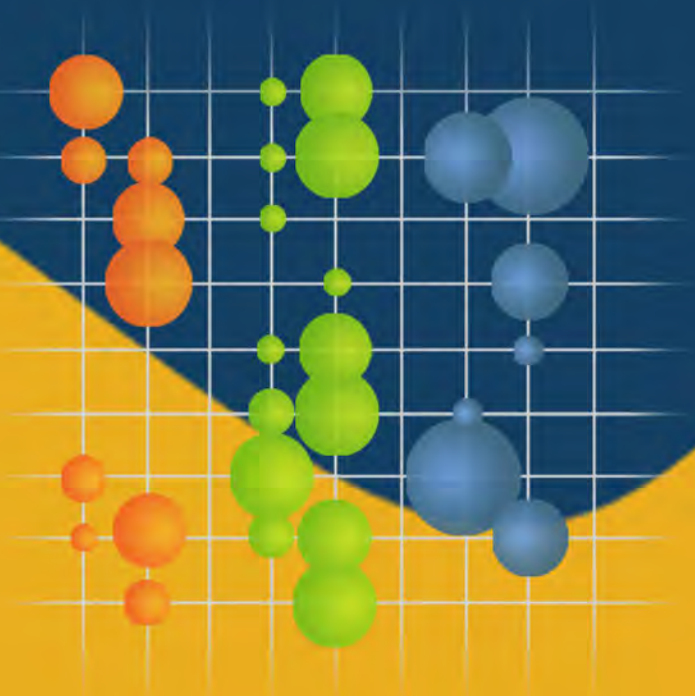

FELIX R. LIBRERO, PhD

WRITING YOUR THESIS
(A Practical Guide for Students)

By

FELIX R. LIBRERO, PhD
Professor of Development Communication



University of the Philippines
OPEN UNIVERSITY
Los Baños, Laguna, Philippines
2012

Writing Your Thesis
By Felix R. Librero

Copyright © 2012 by Felix R. Librero and the University of
the Philippines Open University

Apart from any fair use for the purpose of research or
private study, criticism or review, this publication may be
reproduced, stored or transmitted in any form or by any
means ONLY WITH THE PERMISSION of the author and
the UP Open University.

Published in the Philippines by the UP Open University
Office of Academic Support and Instructional Services
2/F, ICTO/UPOU Building
C.P. Garcia Avenue, Diliman, Quezon City 1101
Telephone (632) 426-1515
Email: oasis@upou.edu.ph

ISBN 978-971-767-210-6

First printing, 2012

Cover design by Eleanor Payawal-Manipol
Layout by Helen Mercado-Creer

Printed in the Philippines

Acknowledgment

To the following, I am indebted:

Dr. Serlie Barroga-Jamias, College of Development Communication, UP Los Baños, for doing an excellent job of editing my manuscript;

Dr. Armind V. Santiago and Dr. Jose R. Lacson, Jr., College of Mass Communication, UP Diliman, for reviewing the manuscript and suggesting very significant refinements insuring that it is worth publishing;

Dr. Jean A. Saludadez, Director of UPOU's Office of Academic Support and Instructional Services, for making very quick decisions in getting this volume published under the imprimatur of UPOU.

Ms. Eleonor Payawal-Manipol, for doing a great job of designing the cover; and

The OASIS staff, and especially, Ms. Helen M. Creer, for a very good job on the layout, as usual; and, finally,

Ms. Ma. Jeanette G. Libro, my wife, for giving me as much time and assistance as I needed in completing the manuscript to beat my personal deadline.

All of the shortcomings of this book, however, are mine.

FELIX R. LIBRERO
September 2011

Dedication

This book is dedicated to

Ma. Jeanette G. Librero, my wife,

and

Al-Francis D. Librero, my son.

Table of Contents

Part I. Writing Your Thesis Proposal, 1

Chapter 1 The Meaning of Research, 3

Definition of Research, 3

Types of Research, 5

Purposive nomenclature of research, 5

Descriptive nomenclature of research, 8

Dualistic nomenclature of research, 9

Chapter 2 Writing The Introductory Chapter of Your Thesis, 11

Description of the Background of the Study, 12

Presenting the Research Problem, 15

 Research problems classified according to practical purposes, 16

 Tips in the selection of a research problem, 17

 Rules in defining a research problem, 19

Formulating the Objectives of the Study, 20

The Hypotheses of Your Thesis, 21

 Meaning of hypothesis, 21

 Types of hypotheses, 22

 Other points to remember about hypotheses, 23

 When to test hypotheses, 24

Describing the Importance of the Study, 25

Delimiting the Study, 26

Defining Terminologies, 28

 Definition by example, 29

 Definition by genus and differentia, 29

 Definition by stipulation, 30

 Definition by constitutive operational analysis, 30

Chapter 3 How to Review the Literature, 33

Basic Guidelines in Reviewing the Literature, 34

 Specific purpose of the review of related literature, 35

 Premises in reviewing the related literature, 36

 Common errors in reviewing the scientific literature, 37

Some Practical Literature Search Strategies, 38

 Using index cards, 40

Other Helpful Rules of Thumb, 47

Chapter 4 Frameworks For Your Thesis, 55

The Research Framework, 55

Theoretical and Conceptual Frameworks, 58

The Operational Framework, 61

Chapter 5 The Methodology Chapter of Your Thesis, 63

The Research Design, 63

 Experimental designs, 64

 Quasi-experimental designs, 67

 Survey research design, 69

 Participant observation, 71

 Content analysis, 72

 Delphi, 73

 Problematique analysis, 74

Describing the Variables of the Study, 75

Describing the Respondents of the Study, 76

Sampling Techniques, 77

 Probability sampling, 78

 Non-probability sampling, 81

 Determining your sample size, 82

The Research Instrument, 82

 The questionnaire, 83

 The interview schedule, 92

 Practical approach to preparing questions, 93

 A word about asking question, 95

Procedure in Collecting the Data, 96

Part II. Writing Your Thesis Manuscript, 99

Chapter 6 The Thesis Manuscript: an Overview, 101

Review Your Thesis Proposal, 101

Conceptual Overview of the Remaining Chapters of Your Thesis, 102

A Word on Interpretation of Data and Information, 104

Establishing the Ambiance of Interpretation, 104

Chapter 7 Analyzing Your Data, 107

Measurement, 107

Nominal scale, 108

Ordinal scale, 109

Interval and ratio scales, 110

Quantitative Analysis, 111

Qualitative Analysis, 112

Summarizing Your Findings, 115

Formulating Your Conclusions, 116

A Word About Making Recommendations for Further Study, 116

Chapter 8 Visualizing Your Results, 121

Use of Statistical Tables, 121

A note on the use of tables, 124

Techniques of Visualizing Research Information, 124

Charts, 124

Graphs, 127

Use of Illustrations and Drawings, 129

Use of Photographs, 130

A Word About Errors in Observation, 131

Chapter 9 Practices in Citing Sources, 135

Citation, 136

Bibliographic Entries, 137

The Issue of Plagiarism, 139

The quote, 144

Paraphrase, 144

Summary, 145

Chapter 10 Mechanics of The Thesis Manuscript, 147

Format, 147

Preliminary Pages, 152

Appendices, 153

Bibliography, 155

Part III. Appendices, 161

Appendix A. Sample Literature Review, 163

Appendix B. Outline for Evaluating a Research Report, 173

Appendix C. Sample Questionnaire, 175

Appendix D. Towards a Methodology for Problematique
Analysis, 191

Appendix E. Getting Published in Academic Journals:
Some Practical Guidelines, 215

About The Author, 237

List of Figures

1. Representation of Inquiry Space or Domain of Inquiry, 10
2. Obverse of Note Sheet, 44
3. Reverse of Note Sheet, 45
4. Modified Note Sheet, 46
5. Sample Review of the Related Literature, 50
6. The Structure of Your Thesis Framework, 57
7. The Stimulus-Response Theory, 58
8. Hypothetical Conceptual Framework, 59
9. Model Showing Stages of Communicating Information Using Four Utilization Methods, 60
10. Theoretical/Conceptual Framework Matrix, 60
11. Sample Factorial Design Matrix, 67
12. Sample Objective-Hypothesis Matrix, 94
13. Flow chart in Translating Research Problem to Conclusions and Recommendations, 103
14. Problematique Map of the Programming Critical Function of a Rural Educational Broadcasting Station, 114
15. Sources and Types of Observation Errors, 133

Preface

This book is written for the Filipino student studying in the Philippines in mind, but it would be useful to non-Filipino students as well. It is a sequel to the book titled *How to Write a Thesis Proposal*, previously written by the author. The original manuscript of the first book was published, in mimeographed form, as Lecture Notes for the course, Introduction to Development Communication Research, in 1984, by the then Department of Development Communication in the UPLB College of Agriculture. This meant that it was written for students of development communication, which was why the original manuscript was highly oriented towards scientific writing.

Early in 1985, the UPLB College of Agriculture Publications Program suggested that it be published by the Program. Hence the First Edition was published in 1985, with only good faith between the author and the Institution (UPLB College of Agriculture Publications Program), as there were no legal documents signed.

A Revised Edition was published in 1996, and a Third Edition in 2003. A Fourth Edition was suggested by the publisher in 2004 but I thought that the third edition was complete according to how it was titled. If I had to update the book, it would have to be retitled so that new appropriate contents may be added. The logical additional content, it was thought, would be a discussion of how thesis data may be analyzed and how the findings may be written up, which are no longer appropriate part of a thesis proposal. This was a good reason to transform a potential Fourth Edition into a new book with a different title.

Hence, this book, *Writing Your Thesis*. It is not completely different from the previous book titled *How To Write a thesis Proposal* because a very substantial part of that book is included in this current title. There are three parts: Part I (Writing Your Thesis Proposal), Part II (Writing Your Thesis Manuscript), Part III (Appendices).

Part I contains much of what the previous book, *How to Write a Thesis Proposal*, included, but it has been completely reorganized and heavily edited. It also contains new material. Expanded explanations and discussions were also added. The previous book, of course, is a logical part of this new book, so it was included.

Part II is a substantial expansion of a small portion of the previous book that dealt with the discussion of results and techniques of data presentation, as well as suggestions for meaningful data analysis and interpretation.

Part III is simply titled Appendices. All of the five appendices discuss important topics related to writing the thesis manuscript, but they could not be appropriately discussed in the various chapters of the new book. There is one appendix added to this volume, which deals with how to get published in an academic journal.

At this point, an important explanation (more of a disclaimer) is needed. This volume has clear leanings towards writing up of scientific research. In fact, the perceptive reader would be able to decipher, as did the reviewers of the manuscript, the fact that this book does not have enough entries and discussion on how to write thesis or research that have employed qualitative strategies. Therefore, this book is far from being comprehensive some may have thought or wished. Indeed, this book is far from being comprehensive and complete. This downside should, in fact, indicate to you that those points missing in this book

are things best addressed in one-on-one discussion with your thesis adviser. Perhaps in the next edition there shall be more extensive discussion of qualitative techniques.

This book's tacit message for you, as thesis students (both graduate and undergraduate), is that you should be doing theses worth publishing and not simply student research good only to satisfy one course or subject in a university class. This book's advocacy is, do a thesis that is worth publishing.

FELIX R. LIBRERO
College, Laguna, Philippines
September 2011

PART I

Writing Your Thesis
Proposal



Chapter 1

The Meaning of Research

Definition of Research

Research is defined as the “careful, diligent, and exhaustive investigation of a specific matter, having as its aim the advancement of mankind’s knowledge” (Manheim, 1977). What is definitely implied in this definition, and which is a basic assumption of any research, is that knowledge is desirable and is preferable to ignorance. More recently, Brew (2001) observed that many definitions of research include the following features (p.21):

1. It is “finding out something and making it public.”
2. It is providing a “means of generating, testing and validating knowledge.”
3. It is a “systematic process of investigation, the general purposes of which is to contribute to the body of knowledge that shapes and guides academic and/or practice disciplines” (cited from Powers and Knapp, 1995).
4. It is “about advancing knowledge and understanding” (cited from Oliver, 1997:3).

Another critical aspect of the definition of research is the distinction between scientific and non-scientific research. The conservatives of science, as may be indicated in the literature, claim that scientific research is that which utilizes the scientific method and non-scientific research is all other research (Manheim, 1977). This claim is a sweeping generalization that is probably no longer absolutely true today. In the past, practitioners of science, who were invariably from the natural sciences, have, perhaps jestingly, claimed that it is the natural sciences that are the true science, while the social sciences are not. This, of course, is no longer the bone of contention among scientists today. Still, Kerlinger (1973) differentiated that which is scientific and non-scientific by defining scientific research as follows: “scientific research is a systematic, controlled, empirical and critical investigation of hypothetical propositions about the presumed relations among natural phenomena.” There is here a clear reference to experimentation, which Kerlinger (1973) has always had bias for. Let us further explore the two points that need emphasis in this definition.

1. When we say that scientific research is systematic and controlled, we mean, in effect, that scientific investigation is so ordered that investigations can have critical confidence in research outcomes. This means that the research process is standardized and the observations exhibit regularity according to the disciplined way of employing the process. It would mean, further, that when we do scientific research, it is as if we can more or less describe what might be expected as an output of the research before the research is completed, which is precisely what Kerlinger (1973) emphasizes.
2. Scientific investigation is empirical, which simply means you must have empirical evidence in support of what you believe to be. If you believe that something is so, you must somehow put your belief to a test outside of yourself to demonstrate that, indeed, that something

you believe in exists. Subjective belief, in other words, must be checked against objective reality. You must always subject your notions to empirical inquiry and test.

It should be pointed out, however, that today there is much less effort in distinguishing between what previously may have been referred to as scientific and non-scientific research. In fact, researchers are agreed that research, whether in the natural or social sciences, do employ rigorous methodologies which is what make them scientific in the first place.

Types of Research

Purposive nomenclature of research

The categorization of research based on what is referred to here as the purposive nomenclature is based on the basic aim of the research. In the past, there were three categories under purposive nomenclature, namely: fundamental (or pure or basic) research, applied research, and action research.

Kumar (2005), however, reports that a recent orientation in the classification of research is the dichotomy between “applications” or “objectives” perspectives on one hand, and “inquiry mode employed” on the other. The general classification labeled “application research” includes under it two subclasses called pure research and applied research.

Research according to application or objectives. As Kumar (2005) points out, this classification includes what we used to discuss separately: fundamental (or pure or basic) research and applied research.

1. *Fundamental or pure research.* From the natural sciences view point, one may say that the purpose of research is the development of theories by discovering broad generalizations or principles. It employs careful sampling procedures in order to extend, by inference, the findings beyond the group or situation studied. It has little concern for application of findings to actual problems in areas considered to be the concern of people other than the investigator. We can say that pure research, which is also called basic research at times, is undertaken to satisfy the curiosity of the researcher or scientist. It is usually carried out in the laboratory. In the behavioral sciences, this type of research has been primarily the activity of clinical psychologists, using animals as subjects. We might emphasize here that laboratory research on humans is considered unethical. Kumar (2005) observes that “pure research involves developing and testing theories and hypotheses that are intellectually challenging to the researcher but may or may not have practical application at the present time or in the future” (p.6).

2. *Applied research.* It has most of the characteristics of fundamental research, including the use of sampling techniques and the subsequent inferences about the target population. However, its purpose is to improve a product or a process – testing theoretical concepts in actual problem situations. Most research undertaken in the social sciences are applied research (Kumar, 2005). They include the following:
 - 2.1 Descriptive research refers to the systematic description of a situation, a problem, phenomenon, service or program, or information about a situation like living conditions in a particular community, or description of attitudes towards an issue. The catch word is “description” that can refer to the description of practically anything.

- 2.2 Correlational research establishes the existence of a relationship between or among variables of the study.
- 2.3 Explanatory research clarifies why and how there is a relationship between situations or phenomena.
- 2.4 Exploratory research explores an area that is little known, or to determine whether or not there are possibilities of undertaking further research in said area.
- 2.5 Feasibility study or pilot study may be undertaken to arrive at a decision as to whether or not a full-blown research on a specific topic or area is necessary or warranted.

Research according to the mode of inquiry. Kumar (2005) classifies under this what we have referred to in the past as “action research.” This is focused on the immediate application of the findings of the research to the solution of an existing problem, not on the development of theory or upon general application. It puts emphasis on a problem, here and now, in a local setting. Its findings are to be evaluated in terms of universal validity, but its purpose is to improve practices, and at the same time, to improve those who try to improve the practices. From the point of view of education research, action research is the “systematic inquiry done to gather information about – and subsequently improve – the ways their particular education setting operates, how they teach, and how well their students learn” (Creswell, 2002). The means it aims to improve practice.

Action research, according to Creswell (2002) has the following characteristics:

1. It focuses on practical issues;
2. It studies research on practices;
3. It is a collaborative activity between researcher and participant;
4. It is a dynamic process of data collection, reflection, and action, moving back and forth;
5. It is a process of developing a plan of action to respond to a practical issue; and
6. It is a sharing of the researcher's report with the local institutions such as schools, community, and other personnel.

Descriptive nomenclature of research

This categorization refers to specific processes in conducting the research. Essentially, there are three categories: historical, descriptive, and experimental.

Historical research describes what was. The process involves investigating, recording the conditions, and interpreting events of the past for the purpose of discovering generalizations that are helpful in understanding the present, and to a limited extent, in anticipating the future.

Descriptive research describes what is. It involves describing, analyzing, and interpreting the conditions that now exist. It involves some kind of comparison and contrast, and may attempt to discover relationships between existing non-manipulated variables.

Experimental research describes what will be when certain variables are carefully controlled or manipulated. The focus is on the relationship of variables. Deliberate manipulation is always a part of the experimental method.

Dualistic nomenclature of research

In the decade of the 70s, researchers were increasingly becoming concerned about research methods that required other categorizations. Guba (1978) offered a typology of research inquiry highlighting the differences in basic approaches. He called these scientific and naturalistic inquiries.

Scientific inquiry. This approach moves towards experimentation. A completely scientific research is complete experimentation, following the requirements of fundamental or basic research.

Naturalistic inquiry. This is a research approach that puts emphasis on qualitative research and in the observation of behavior under natural settings. In a complete naturalistic inquiry design, there are no controls. You observe, say, the behavior of humans under the most natural conditions.

Guba's conceptualization of these two approaches is shown in Figure 1.

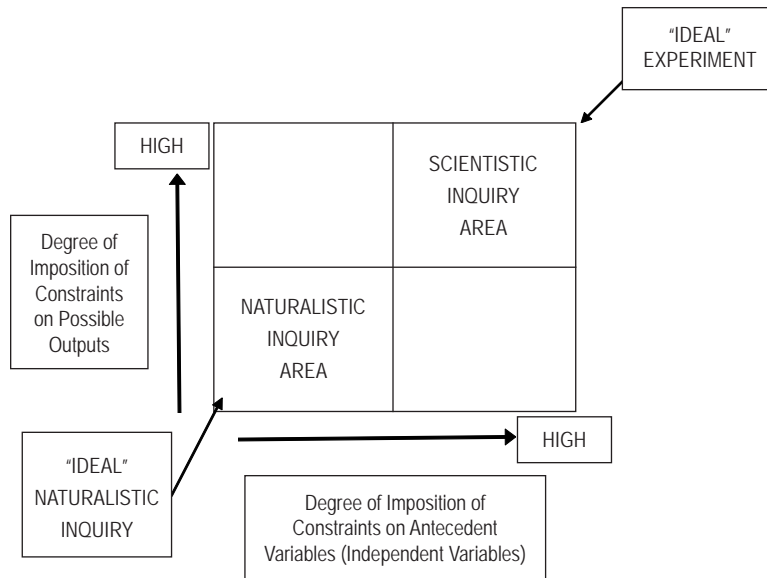

Figure 1. Representation of inquiry space or domain of inquiry*

*Adopted from Guba (1978), p. 10, based on Williems & Raush (1968), p. 47.

We have discussed here three nomenclatures of research, but these are not really completely mutually exclusive. In fact, it is entirely possible that your thesis, for example, may employ qualitative techniques (as in the naturalistic strategy) in trying to discover solutions to an existing problem (as highlighted under action research), which may have appeared much earlier in time and may have, in fact, been solved in those times (historical). Most research projects, indeed, cut across the various research classifications. Therefore, our classifications are useful as tools for deeper analysis of the research process. You are not going to classify your theses according to these classifications of research, but it is good to understand the type of research you are doing.

Chapter 2

Writing The Introductory Chapter of Your Thesis

Most authors of books on research today agree that a significant consideration in the preparation of the introductory chapter of your thesis proposal must be the immediate discussion of the research problem. However, it is not as simple as saying right away “The problem of this research is . . .” In developing your introductory chapter, consider the following guidelines:

1. Your introduction briefly discusses the historical developments of events regarding the specific topic you are interested to study. What is important here is that you should be able to argue that your topic has a certain level of significance that warrants its study. Show that over the years, either the topic has been fully developed as a research area as indicated by a succession of significant events, or that it has not been fully studied in spite of its importance as a topic. However, if you argue that it has been fully studied, you will have to justify strongly why you are still studying it perhaps by pointing out flaws in its development or in the literature (research gaps).

2. Describe the basic assumptions that led you to study the topic. This should build up on the arguments you may have presented earlier. You would be able to present powerful assumptions if you base your arguments on the existing body of knowledge that indicates that there may be flaws in the scientific literature.
3. Justify why you think there is still a need to further study the topic. Your description of the historical development of events surrounding the topic should help you in your justification. This is especially true if there are indications as highlighted by current knowledge that existing issues have not been fully studied and resolved, or that there are new issues that need to be studied.
4. Briefly describe how you intend to go about conducting the study. Is your study going to be an experiment, a case analysis, or a survey? This brief description should give the reader an idea of how you intend to pursue the study given, for example, the topic's complexity or significance relative to the existing body of knowledge. In other words, upon reading your proposal, would your readers gain a clear understanding of why the topic is important and why there is a need to study it?

Description of the Background of the Study

This should be the first section of Chapter I. It normally contains basic background information and assumptions that show the state of the art of a particular field or endeavor. This section also discusses, briefly what you intend to do after establishing the need to provide bridges between what may already be known about the field and what still needs to be known. To drive home this point, here is a hypothetical

example, pushed to its extreme, of how this section might be structured or organized:

Rationale of the Study

Research worldwide indicates that there is a clear influence of membership in a social networking group within a multimedia organization in enhancing greater participation of organization members in the various operational activities of the organization (Amadeus, 2000). Studies in North America and Europe indicate that members of social networks, particularly Tweeter are more active participants in performing activities required by their respective organizations (Forbes, 2006). In Asia, however, there is a dearth of empirically-based information on this topic (Guzman, 2008). Therefore, this study aims to determine if there is a distinct relationship between membership in a social network and the nature of performance in the operations of the organization.

As the section title indicates, this section provides the reason or justification for the study, as well as the structure to be followed in conducting the study. In other words, it is a bird's eye-view of the proposed study. It is important that you can describe clearly but very briefly the background of your proposed thesis to demonstrate your broad and deep understanding of your research topic.

Here is an example of how this section may be written up. It was taken from a master's thesis titled *Exploratory Study of Storymaps as Technique of Generating Information About Farmers' Realities*.

The current study attempts to develop a culturally appropriate data gathering technique in the farms in view of the limitations of present research methods such as surveys and interviews in capturing farmers' and rural audiences' realities.

While the power of survey research lies in its replicability, quantifiability and generalizability, its weakness, particularly with rural audiences, is its inability to penetrate deep into their "realities." This stems from its top-down nature, which assumes many things about the subjects' realities even before the actual encounter with the subjects; and from farmers' own inability to identify and articulate their circumstances through the method and the researcher.

The present study maintains that surveys and interviews remain potent tools for social research, only that they must be used for what they were meant for. Despite the criticisms in its methodology, the survey remains a potent tool for social research, if used appropriately. However, for want of other data gathering tools, survey research has been used as an all-around tool, even in situations or on people where it is not appropriate. It is in these instances that survey research comes under fire.

Recognizing the limitations of survey research, especially among farming and rural subjects, it therefore becomes imperative to develop new techniques to answer these limitations. There is now a growing trend towards the use of "other" methods and techniques outside the survey method.

These involve the combining of both quantitative and qualitative research methods, as well as the re-structuring of the traditional top-downward power relationship between the researcher and the researched toward a more democratic and horizontal relationship.

The study attempts to respond to these needs. Barroga, R. (1991)

Presenting the Research Problem

This is the section of the chapter that is usually titled “Problem Statement” or “Statement of the Problem.” Most books today that deal with the preparation of research proposals suggest that the research problem be presented immediately, as in presenting it in the introductory chapter of the proposal. The reader must know right away what research problem is going to be resolved by the proposal. That is to say, your thesis adviser needs to know what you are working on so that he/she may be able to give you sound advice on how you shall proceed undertaking your thesis. There are a number of ways of presenting the problem. Some researchers would present, in narrative form, the situation putting emphasis on the existence of a problem and describing gaps in already existing body of literature. Others would simply list a set of questions that need to be answered.

A problem is a statement that asks: “what relation exists between two or more variables?” (Kerlinger, 1973). Kerlinger says that a scientific problem always states a relation between two variables. While there may be no one “right” way to state a problem, certain characteristics of problems can be learned and put to good advantage. The criteria for good research problems, according to Kerlinger (1973) are as follows:

1. “The problem should express a relation between two or more variables” (p. 17).
2. State the problem in question form because it is easiest understood that way. “Questions have the virtue of posing the problem directly” (p. 18).

3. The third criterion is frequently unsatisfied although not difficult to do. Here is how Kerlinger (1973) puts it: "It demands that the problem and the problem statement should be such as to imply possibilities for empirical testing. A problem that does not contain implications for testing its stated relations of variables is not a scientific problem. This means not only that an actual relation is stated but also that the variables of the relation can somehow be measured" (p. 18).

Research problems classified according to practical purposes

According to the Columbia University Bureau of Applied Social Research, research problems may be classified according to practical purposes (Merton, 1973):

Diagnostic. You determine if an action is required. You look at the magnitude and extent of the problems, changes and trends since the past appraisal (e.g., changes in level of social tensions in the community), and differences among affected groups, areas, and institutions. Simply put, and from a medical orientation point, what is your diagnosis of the research problem or situation? The term "diagnostic" has a ring of certainty to it, so that when you describe your research problem you must do so in precise terms.

Prognostic. You forecast trends in order to plan for future needs. Among the things you can look into, for example, would include analyzing market trends among affected groups, areas, and institutions. Your medical doctor would say, "this is the prognosis" or a friend would ask you, "what is the prognosis?"

Differential prognosis. In this category, you determine choices among alternatives. Very frequently, these would refer to policy alternatives. Example: public reaction to deregulation of telecommunications. There is here a tinge of making choices from alternative possible solutions to a problem situation.

Evaluative. This is basically the appraisal of the effectiveness of programs. Example: assessing the effectiveness of the communication campaign on environmental issues. When we say “evaluative,” we are essentially dealing with having to make judgments about a phenomenon or condition, especially that which makes reference to one being better than another.

General background data. This category has something to do with studies of general usefulness such as population census.

Educative research. This deals with issues on providing information to the public for the purpose of countering misconceptions.

Tips in the selection of a research problem

As thesis students, you may find it difficult at times to decide what research to undertake, more so what specific title to work on. Not a few have complained, “I can’t think of a problem” to which I have jestingly responded, “good for you if you don’t have a problem.” Perhaps the difficulty lies in the fact that not a few thesis students depend largely on what potential research titles they can think of instead of trying to gain a clear understanding of the research literature on the topic of their interest. A clear understanding of what gaps exist in the current literature is still the best way to identify potential research problems to work on.

The following tips should help you select your research problem:

1. A thorough understanding of the known facts and accepted ideas in the field being pursued is a necessity. That is to say, you must try to be on top of your discipline. Always keep abreast of the recent developments in your field.
2. Use your natural curiosity as guide for selecting a problem. Of course, satisfaction of personal curiosity is a desirable incentive in selecting a topic to study, but this is not all. The presumption is that your curiosity rises as you gain a deeper understanding of the gaps in the body of knowledge of your field.
3. Young and inexperienced researchers should choose short and clear topics. Such researchers may not have the necessary capability to deal with broad and complicated research problems. All thesis students have this feeling that their respective theses will solve the problems of the world. This must be one of the reasons why you almost always think of very broad research issues because of the idea that your thesis, being your first professional work, will become very important and will open all doors for you professionally. It is, indeed, motivating to think in those terms. But is also always advisable to keep your feet on the ground. Again, do not try to solve the problems of the world by yourself with your thesis. But do try to do a good job of your thesis so that you can contribute to the increasing body of knowledge and ultimately help your discipline advance.

It is very important that you clarify your research problem. Here are five questions that will help you clarify your research problem:

1. Is the problem interesting? It is better to work on something that interests you.
2. Is the problem new? Choose a problem that is relatively new but has not been fully studied.
3. Will the study add to knowledge? You must be convinced that by doing the study you will contribute new knowledge.
4. Is the problem feasible? Choose problems that you can manage, those that can be feasibly undertaken.
5. Has anyone else had a prior claim to it? You may not be able to claim credit for a research problem that has already been studied previously by other researchers, but you may be able to arrive at other findings.

These are all practical questions that are designed to help you clarify the research problem you would want to work. These are all important because you can not do a good job of your thesis if your research problem is not clear, especially to yourself.

Rules in defining a research problem

These rules should serve to guide you in defining your research problem:

1. Be sure that the topic you choose is neither too vague nor too broad in scope.

2. To make the problem clearer and more understandable, state it as a question that will require a definite answer.
3. Carefully state the limits of the problem, eliminating all aspects and factors that will not be considered in the study. Sometimes some thesis students are unable to exclude from the thesis certain aspects of the topic because of the feeling that they must consider everything about the thesis topic. Well, the more you are unable to delimit your study, the more likely you will not be able to do a good job of it.
4. Define any special term that must be used in the statement of the problem.

Formulating the Objectives of the Study

Objectives must be specific and achievable. It is always wise to list them, no more than a sentence a piece, in approximate order of their importance or potential contributions. The objectives form a basis for judging the remainder of the proposal. Objectives set the stage for showing how one intends to solve or contribute to the solution of a problem. The objectives must neatly fit into the problem statement.

There are two common errors in writing objectives. First, they are vaguely stated generalities rather than clear cut criteria. Second, they are not presented according to priority.

In the thesis cited earlier, the author formulated his objectives as follows:

The study shall explore the potentials of storymaps as a technique of generating information about farmers' realities in order to:

1. *Explore an alternative technique in generating information about farmers' realities;*
2. *Develop a technique to encourage greater involvement of the research participants in the research process;*
3. *Discover from the research participants the causes of their low income and their solutions to this; and*
4. *Provide useful, in-depth information as feedback on the government's on-going rice production program.*

There is always a tendency to state your objectives too broadly. The danger here is that you will ultimately find it more difficult to achieve your objectives if you state them too broadly. Besides, you will also find it difficult to determine specific measurements that you will need to decide whether or not you have met your objectives.

The Hypotheses of Your Thesis

Meaning of hypothesis

A hypothesis is a conjectural statement of the relation between two or more variables (Kerlinger, 1973). It is always in declarative sentence form, and it relates variables. There are two criteria for "good" hypotheses:

1. Hypotheses are statements about the relation between variables.

2. Hypotheses carry clear implications for testing the stated relationships.

These criteria mean that the hypothesis statements contain two or more variables that are measurable or potentially measurable and that they specify how the variables are related. A statement that lacks either or both these characteristics is not a hypothesis in the scientific sense (Kerlinger, 1973).

Types of hypotheses

There are two types of hypotheses: null hypothesis (H_0) and alternative hypothesis (H_1) or research hypothesis.

A null hypothesis (H_0) is a non-directional statement of condition between two variables. It states that “there is no significant difference between” two parameters. An example of a null hypothesis is:

There is no significant difference between the scores obtained by respondents who viewed the presentation and the scores of the respondents who did not view the presentation.

On the other hand, the alternative hypothesis (H_1) is a directional statement of a relationship between variables, which may be stated as follows:

Respondents who view the presentation will tend to obtain higher scores than respondents who will not view the presentation.

The alternative hypothesis is also called “research hypothesis” or “substantive hypothesis.”

In brief, the research hypothesis (or alternative hypothesis) states a relationship between two or more variables that the research predicts will emerge. The null hypothesis states that no relationship exists between the variables concerned and that any observed relation is only a function of chance.

Other points to remember about hypotheses

1. The purpose of deriving a hypothesis is to deduce the consequences. You do not test the hypothesis, you test the consequences. Therefore, the condition “if this is so, then that will be.” It is very important to be able to recognize the consequences of a hypothesis.
2. Hypotheses are not supposed to be proven, they are supposed to be confirmed. While they may not be verifiable, hypotheses make possibility statements that can be confirmed.
3. A basic question to ask is: how useful is the hypothesis? What roots does it have in theory? Most authors believe that the broader the scope of the hypothesis, the more useful it is. However, if it is too broad, it becomes too complex to confirm or falsify. This can be overwhelming to beginners, like thesis students.
4. What place does the hypothesis have in a hierarchy of facts and theories? High? Low? It may have little immediate utility, but it may provide a much needed answer to a gap in theory.

5. A hypothesis should be stated simply. Most researchers tend to state hypotheses with sophistication, but it is important that hypothetical statements are made simple enough. The simpler the hypothesis is stated, the easier it is to confirm or falsify it. This is also part of the reason why a hypothetical statement must contain only two variables, one being the cause and the other the effect so that testing becomes more manageable.

When to test hypotheses

Suppose you are conducting an audience survey for a particular radio program called “Good Morning Philippines” to find out what proportion of the audience is listening to the program. Because of your training in scientific research, you have to formulate a set of hypotheses that you must test. One of these hypotheses is: “there is no significant difference between the number of respondents listening to “Good Morning Philippines” and the number of respondents not listening to “Good Morning Philippines.”

Your survey data show that 80% of the respondents listened and 20% did not. You subjected these data to statistical testing and found that there was significant difference between the number of those listening to the radio program and the number of those not listening to the radio program. This being the case, you rejected the hypothesis and concluded that there was, in fact, a difference between the number of those listening and those not listening. So what does this mean?

Question: was testing the hypothesis necessary? Would you not have arrived at the same conclusion by simply looking at the figures and without having to go through the motions of testing your hypothesis? How much more meaningful was your conclusion due to the rejection of your hypothesis?

The point is that when you are certain you can arrive at a very accurate and meaningful conclusion by even simply looking at the figures, you really do not have to go through the motions of hypothesizing and testing your hypothesis. Doing so would not make any difference at all. This is simply common sense. Where you are simply describing an observable situation or condition, there is no need to hypothesize. It would be different were you to look at a more complicated interactions of variables.

So now, how would you know that you need to hypothesize and have your hypothesis tested? A simple rule of thumb is this: you need to hypothesize about the relationships of variables that are indicated in your conceptual framework. The moment you have a theoretical or conceptual framework, it means that you have introduced certain assumptions (hypotheses) regarding the relationship among your variables. To prove that your assumptions are correct, you need to test them.

There are studies that do not really need to test hypotheses. Studies that aim to describe do not need to test any hypothesis. For example, a simple survey of media availability in an informal settlers area does not really need to prove any hypothesis. A case study of a particular phenomenon would not need to have hypotheses. Rarely do historical studies require hypotheses.

Describing the Importance of the Study

This is a set of statements about the possible contributions of the study. You must be able to indicate the generalizability of the research findings, and point to the way in which the research would contribute to theory or knowledge of a general or specific phenomenon. You must be able to

describe the value of specific applications of knowledge to be gained and the potential importance of these applications. Do not, however, over-attribute extremely important advantages to your study. This is a common error among thesis students who usually claim that their studies (sometimes too small or limited) would solve an important problem. It may not be proper, for example, to claim that your little thesis shall “solve the mismanagement problems” of the Department of Science and Technology, or statements of that nature. State what specific important contributions your study can offer but do not over-state its contributions to the body of knowledge. Always cushion your statements with guarded phrases like, “results of this study would, hopefully, contribute to a better understanding of the issues involved in the appropriate utilization of data sets in the Department of Agriculture,” or something to that effect.

Here is how the author of the thesis cited earlier clarified the importance of his study.

The development of more culturally appropriate data gathering techniques at the farm level could strengthen existing quantitative research methods, such as the survey, and contribute to the development of more responsive social policies and development strategies.

Note the use of terms or phrases like “could strengthen” or “contribute to the development

Delimiting the Study

Very often, research students fail to identify the boundaries of their research. It is important that you describe the limitations of your study. In other words, this section discusses the weaknesses of the study in terms of methodology and generalizability of the results to be obtained from the study. Most theses are limited by the size

of sample, the locale of the research, and some other factors. These things must be pointed out so that the results could be interpreted appropriately. This section is also frequently referred to as the *Scope and Limitations of the Study* section.

The thesis cited earlier has these limitations:

Due to the exploratory nature of the study, the findings will remain inconclusive until more rigorous tests shall have been made on the technique. As in the case study research design, the study is limited in its representativeness and generalizability due to the small sample and rudimentary analytical procedures. However, its strength lies in its high internal validity.

Just a reminder. Simply because this section of your thesis is titled “Limitations of the Study,” does not mean you have to list all possible wrong things, including minor ones, that you may have committed in doing the research (and making them sound like they are major and unforgivable infirmities of the research). Do not over-do discussion of the limitations of your study. If you say too many negative things about your thesis proposal or manuscript, your readers would tend to ask, “so, why will you do or why did you do the study at all?” So, how do you write this section? A good piece of advice is, use guarded phrases and statements like “it appears that ...” or “the calculated correlation value indicates that ...” and the like. That way, you are making a statement about your observation, but at the same time, telling your reader that he/she can look at your observation from another viewpoint or perhaps even refine the analysis to arrive at a better understanding of your result.

The useful statement of the “Limitation of the Study” deals with shortcomings in terms perhaps of methodologies such as described by Barroga (1991), or perhaps some problems with sampling. In fact, most theses have very small sample sizes, which make their finding very inconclusive. The statement of limitations is a caution to readers to take the results of your thesis in consideration of its shortcoming, for example, in terms of its sample size. Look at this hypothetical example:

Scope and Limitations of the Study

In this study, the researcher intended to make a clear and categorical statement that all the political beliefs of Overseas Filipino Workers (OFWs) are influenced mainly by the blog statements of a particular Filipino blogger based in Metro Manila. However, this generalization could not be made considering that the study included in its analysis the blogsite only of a specific blogger. Besides, the time coverage of the study was only for six months and that the topics discussed in the blogsite focused mainly on just two major political phenomena in the Philippines in the duration of the study. While, it was not possible to make informed and accurate conclusions as intended, the results do indicate a possible trend of influence that the blogsite might have on OFWs. There is need for further study to arrive at more conclusive evidence in support of this assumption.

Defining Terminologies

Before launching an investigation and when writing up a research proposal or report, you must define rigorously the meaning of the terms used in the statement of the problem and in the hypotheses. The objective is to write a clear, precise definition that will call up the same core of meaning

to all competent researchers in the field. Some of the techniques of defining terms (Kerlinger, 1973) are discussed here.

Definition by example

The most direct way to close the gap between a word symbol and sensory experience is to point to it or to introduce a specimen or picture of it. Concrete word examples to which a term can be correctly applied give one some understanding of what is meant. For example, a university administrator may be defined as a college dean. Here, we point out to some other things in order to define the term.

Definition by genus and differentia

Identifying the boundaries and stating the “essence of a thing” can be done by indicating its genus, or the larger class in which the referent is included or subsumed, and then by indicating how it differs from other subclasses of the same genus. For example, if we define “full professor” we may move up first to the next larger class, “teacher”, and then state the essential difference to eliminate all teachers who are not full professors. Therefore, we might state, for example, that “full professors are teachers of the highest academic rank in institutions of higher learning.” This definition distinguishes full professors from teachers of lower rank. Definition by genus and differentia is especially useful in areas where phenomena have been structurally classified and a number of large-class terms have been established whose meanings are not in serious dispute.

Definition by stipulation

An initial step that can be taken in defining the terms in a study is to ascertain how the terms (concepts, constructs, properties, variables) are defined in similar research studies or in the specialized pedagogical, statistical, and psychological dictionaries that have been completed. These definitions can be used as guides but should not be borrowed blindly. As a researcher, you are responsible for stipulating precisely how a concept will be applied in a particular study. A dictionary may define a gifted underachiever as “a child with high intellectual ability who does not achieve on a level commensurate with his ability.” The researcher may stipulate that the gifted underachiever in a particular study is a student who has an IQ of 130 or higher but reads at a level one year below the community level. Defining an abstract concept that is not directly observable, but rather referred from behavior is not an easy task.

An adequate definition lays bare essential differentiating characteristics of the concept, so that through them, the term in question is clearly related to the intended referent and distinguished from all other concepts. The use of common words in research can cause as much confusion as abstract concepts. This means that common terms may also need to be defined.

Definition by constitutive operational analysis

Constitutive definitions define constructs by describing how they are linked to other constructs in a set (e.g., intelligence is the product of the interaction of a person’s heredity and environment), or by ascribing their key characteristics (e.g., intelligence is the ability to deal with tasks involving abstractions).

Sometimes referred to as operational definition, this kind of definition links theoretical constructs with observable indicants of them. They ascribe meaning to constructs by specifying the operations necessary to achieve certain objectives. For example, you may define grade point average as the ratio of the sum of numerical grade multiplied by units earned, and the total number of units. This may be expressed in the following formula:

$$\text{GPA} = \frac{\text{Sum of (numerical grade) x (number of units for course)}}{\text{Total number of units for the semestral period}}$$

In other words, operational definition is stated in terms of steps and operations or procedures that must be carried out in observing or measuring that which is being defined. Operational definition refers to how you will apply the concept specifically in your study.



Chapter 3

How to Review the Literature

Among researchers, and especially thesis students, the review of the literature is a significant task. Indeed, while in Graduate School, this author's professor in research once said, "the only publishable portion of your thesis is the review of literature," which, of course, is not always true but gives a clear indication of its importance in the research process. In fact, in preparing your thesis, the review of the literature is perhaps the first task you need to do. Just what is the review of the literature?

A review of the literature is an "account of what has been published on a topic by accredited scholars and researchers" (HYPERLINK "<http://www.awc.metu.edu.tr>"; HYPERLINK "<http://en.wikipedia.org>"). Other institutions, like the University of Toronto in Canada, highlight, as well, that the review of the related literature is a synthesis of the published materials about a particular research topic (HYPERLINK "<http://ww.writing.utoronto.ca>"). Implied in this description or definition is the idea that a comprehensive review of the literature would greatly help the thesis student in determining the research gaps in the area of his/her study, as well as in providing a synthesis

of the latest developments in the discipline. This is the reason why researchers would be interested in how other researchers, including a thesis students, treat the literature related to their studies. These issues are discussed in more detail through this chapter.

Basic Guidelines in Reviewing the Literature

As a beginning researcher, you may have problems with the review of the scientific literature related to your study. This is usually called the “Review of the Related Literature” because the literature that you will review and synthesize is normally that which is only related to your specific study. Reviewing the literature can be a nightmare if you do not understand fully why you are doing it, and how you are going to do it.

Over the years, we have seen many thesis students frequently having problems with voluminous materials collected and notes from various readings and sources. Collecting too much materials in the course of your reading of the literature and not knowing what to do with these materials later is a common experience. This is the result of indiscriminate collection of ideas from whatever you may have read. We can actually categorize into two groups students who may be reviewing the literature according to the following: first, those who amass voluminous amounts of materials and will not know what to do with them later, and those who do not know where to find the necessary materials. In both cases, the task of reviewing the literature becomes unwieldy and unnerving. To avoid these pitfalls, you must do certain things to facilitate your task.

It is not necessary to review all the literature in the field especially if you are dealing with only a specific research topic. For example, much of the research literature in environmental science will be unnecessary in a specific study about climate change. What you need are materials that have direct relevance to the study you are going to conduct, i.e., reports of changes in weather patterns in selected areas of the country, changing rainfall patterns in various countries of the region, updated information of melting glaciers and ice caps, etc.. This is the reason why the chapter on literature review is titled “Review of the Related Literature.” What you are expected to review are only those that have relation to your study. The trick is to learn to discriminate what information may help you in your research and what information may be irrelevant.

The review of related literature is an extremely important part of your thesis. In fact, in many cases, it is probably the most publishable part of your thesis.

Specific purpose of the review of related literature

Frequently, thesis students fail to see the significance of the review of related literature. Sometimes, they consider this as an unnecessary component of the thesis requirement, hence they do not take it seriously. There is more than meets the eye in the literature review. In fact, the review of related literature is normally about 25 percent of the entire thesis. In any case, why do you have to review the related literature? The five basic purposes of the literature review are as follows:

1. The literature review expands the introductory chapter of your thesis, and normally helps in determining the research gaps in the particular area of interest

that is addressed by the thesis. A very fundamental consideration is the question, what is the issue?

2. The literature helps to further define the research problem. Frequently, you will realize that the literature review has partially answered your research questions.
3. The literature review provides the background and a clear discussion of the theoretical basis for your research (thesis) problem.
4. The literature review will help you interpret the results of your study.
5. The literature review will help you outline the implications of your study.

Premises in reviewing the related literature

Remember these four important points when you review the literature that may be related to your study:

1. The literature review must provide, though briefly, a historical background of the subject you are going to study. This includes any material relevant to the content of the study. It should present a clear background of the topic of study.
2. The literature review must adequately present any and all relevant materials that are available, showing the difficulty or practicality of the problem, the research design, procedures, instruments, and analyses employed by the studies being reviewed. The review should also present an appropriate integration or synthesis of the materials, thereby providing an appropriate synthesis of the literatures that have been reviewed.

3. The literature review should help developing the theoretical framework. This may be done with the clear statement of assumptions.
4. The review of related literature must present a summary in relation to the model or framework being considered for the study. In other words, what is distinct about the literature?

Common errors in reviewing the scientific literature

There are three common errors that thesis students regularly commit when reviewing the literature related to their studies. These are:

1. Too frequently, thesis students rely solely on secondary materials or sources, such as research abstracts, literature reviews done by other researchers, and the like. Frequently, they sometimes simply copy someone else's review of the literature, which has become very easy to do in the age of the "cut-and-paste" technology (Librero, 2010). This could have serious repercussions because there is a chance that the reviewer you may be referring to might have interpreted the original material differently from the way you would. You would also be committing plagiarism if you just cut and paste what is available, say, from the Internet. It is always wise to refer to the original material and properly cite it in your review or in your study.
2. Very frequently, researchers concentrate on the findings in research reports. This is a serious error because if you look at the findings alone, you are likely to be misled by impressive statistics. The important parts of the research reports that you must analyze critically are the

over-all methodology, sampling, research design and methods of analyses. It is a mistake to read only the results reported. Professionals who read your thesis will always want to see how you treated the scientific literature related to your study because this would tell them whether or not you are on top of your field. If you treated the literature lousily, it will almost always mean that your thesis may have been lousily undertaken and written, and perhaps not really worth the reader's while.

3. Researchers usually overlook sources particularly those from countries other than the developed countries. It may be that materials from less developed countries are more relevant to your specific study than those from developed countries. For some reason, many researchers in the developing world almost always depend on the literature from the developed countries. This unfortunate habit seems to continue from the past when there were practically no research reportedly undertaken by professionals and academics in the developing countries. This is no longer true today. In fact, researchers, even from the developed countries, working on topics that originate from the developing world will find much more relevant materials in developing countries.

Some Practical Literature Search Strategies

Reviewing the literature is a tedious and sometimes frustrating task. However, there are ways of making this task easier, even more enjoyable, and certainly more meaningful.

1. Break out of the pool of literature in the field. Do this especially when there is thin literature about your specific thesis topic. You can find highly relevant materials in other fields. For example, if you are studying color preference, say, among rice farmers, you may not find many research reports on the same topic as there may not have been studies on this specific topic in the past. But certainly you will find highly relevant materials in psychology and the arts. What you find from those fields become part of your expanded literature. Now, using materials from related disciplines is an indication that you have exerted enough efforts to check the literature in your discipline that may be associated to your study. This is an indicator for diligence and resourcefulness as a researcher and as an academic.
2. To understand the relationship between available literature better, put together all the materials (your notes on index cards or your folders in the computer) that deal with similar topics. This way, you can easily relate the studies with one another. You can also interpret a combination of data and sets or information. You will need to do this when you discuss the review of the literature in your thesis proposal or manuscript.
3. Normally, books in the library are arranged systematically. To use the library effectively and efficiently, you need to understand the system of cataloging employed by the library. From the card catalog, you will be able to identify a book that is closely related to your study. Go to the shelf and pick out the book you have identified. The materials in this book will have supporting materials in other books on the same shelf. Look at other books located above, below, to the right, and to the left of the book you have picked out. They will contain relevant materials.

Here is a general rule in searching for materials. When you are not sure about the availability of materials in your research topic, refer to the list of references at the end of a journal article you have found. Those references will give you the needed relevant materials as well.

Using index cards

Historically, researchers, particularly student researchers, used pieces of writing sheets on which they could put on their notes about what they read from various sources. The most convenient piece of paper they could use is the index card. There are two types of index cards that you can use, namely: bibliographic cards and the subject matter cards.

The bibliographic card is a 3"x5" index card on which you write the correct and complete bibliographic citation of all the materials you have reviewed. On this card, you should also jot down the library call number of the book or journal so that if you have to go back to it again, you will easily find it without going through the card catalog once more. In writing your bibliographic citation, follow consistently the style recommended by your school.

In today's world, use of index cards is pretty much old stuff - very "Jurassic," indeed. As thesis students today, you would feel much more at home with your laptops, Tabs, or even smart phones, when taking down notes from your readings in libraries or other places. In fact, it is not a bad idea at all if you could include in your gathering of information, as part of your literature review, pictures (with your gadgets) of your information sources. As you go about searching the literature from various sources and places, you may even simply send your notes to your computer at home, which would consolidate the information you have transmitted from anywhere.

In any case, here are sample entries on the 3"x5" index card, should you still feel comfortable with such use:

Habito-Cadiz, Ma. Celeste. (1991). *Educational Communication for Development*. College, Laguna: UPLBCA Publications Program.

Flinn, Alice J. and Juan F. Jamias. (1984). Socio-cultural factors influencing professional communication between UPLB and IRRI researchers. *Devcom Quarterly* (Jan-Mar 1984), II(1): 1-10.

The subject matter card is a 5"x8" index card that you can use in taking down notes, quotations or paraphrased materials. If you are noting down the summary of the reviewed material, make sure that you include information on the following items:

- research design
- respondents and how they were chosen
- tasks required of respondents materials used in the study
- methods of data collection
- methods of data analysis

It is, however, suggested, that you use one card for each major idea so that you will find your materials easier to organize later on.

When taking down quotes or paraphrasing materials, be sure to include only one idea for each card. When quoting, copy the material verbatim and indicate the page number where you got the quoted material. As much as possible, each card must have the complete citation of the source.

Here are examples of entries in the 5" x 8" cards:

Direct quotes

Habito-Cadiz, 1991, p. 39.

Often ignored, the object media have potentials in development communication because they can be used to present ideas and procedures concretely.

Synthesis or paraphrased entry

Flinn & Jamias, 1982

In a study examining the sociocultural factors influencing professional communication between researchers of UPLB and IRRI, Flinn (1984) found that "nationality appeared to be the most important sociocultural determinant of differences in communication." In the UPLB-IRRI communication setting, there are many nationalities which imply many cultural differences.

In actual practice, many students do not like to use index cards. Even these get lost easily. Instead, they use whatever writing material that happens to be available at the time they need it, usually sheets of paper, usually recycled. These ordinary sheets of paper, which normally would come in different sizes and shapes, tend to get lost very easily. However, it is possible to use these sheets more systematically.

For at least three major research projects which the author has undertaken, note sheets were used very effectively. These note sheets were specifically designed for the specific research projects. Two samples are shown in Figures 2 & 3.

Project Title: SYNTHESIS OF DEVCOM RESEARCH	
<p>Bibliographic Citation: Adan, William R. (1984). The communication support to the fisheries development program of the Philippines. PhD Thesis. University of the Philippines Los Baños.</p>	<p>Topic: Media Research Categ: Policy Research Library: DDC Reading Room Cat. No. P-12</p>
<p>Objectives of the Study:</p> <ol style="list-style-type: none"> 1. To describe the structure and processes of communication support to the national fishery development program; 2. To assess the communication resources of the national agency that implements the program and identify the communication needs, problems and organizational constraints that affects its performance; 3. To determine the consequences of communication support and related organizational factors from the viewpoint of communication workers and clients in the fishery industry; and 4. To analyze existing policies governing the organization and use of communication resources capability in fisheries. 	
<p>Theoretical/Conceptual Framework: The basic focus of economic productivity is innovation (Villegas, 1981). The effectiveness of communication depends on the nature of the innovation. Through this trend of thought, the role played by communication can be traced in support of development. For analysis, communication was categorized into material, manpower and systems support. Systems support was broken into resource linking and extension delivery system.</p>	
Methodology	
<p><i>Research design:</i> Survey</p>	<p><i>Research Locale:</i> BFAR Central, Regional, and Provincial offices, coastal provinces in Region 10.</p>
<p><i>Size of Sample & Description of respondents:</i> Sixty-eight communication and extension work personnel of BFAR and 200 clients of the Bureau in the municipal, commercial, and inland fishery sectors.</p>	<p><i>Sampling Technique:</i> Purposive sampling was used in selecting BFAR personnel, a multi-stage sampling method in choosing sampling units in two fishing villages.</p>
<p><i>Independent variables:</i></p>	<p><i>Dependent Variables:</i></p>
<p><i>Research Instrument:</i> The study used a combination of interview schedules, non-participant observation techniques, in field situation, and document analysis.</p>	
<p><i>Duration and Manner of Data Collection:</i> Document search started before the survey proper in the last week of April 1983 and lasted until mid-August 1983. Six students were hired as interviewers. They were given an orientation on the purpose and scope of the study and on the proper conduct of an interview. They went through an interview dry-run in a fishing village to correct some problem areas in the interview schedule. BFAR personnel were interviewed personally by the researcher.</p>	

Figure 2. Obverse of Note Sheet

<p><i>Specific Statistical analysis Employed:</i></p> <p>Descriptive statistics, e.g., measures of central tendencies (frequencies, percentages and arithmetic means) were used.</p>	<p><i>Other Forms of Analysis:</i></p> <p>Normative analysis of the data generated using ideal-types.</p>
<p><i>Summary of Findings:</i></p> <p>The inflow and outflow of information of the country's fisheries development program had been very limited due to the lack of linkage mechanism from both resources and user information system of the communication production network. Inefficient and ineffective communication effort was inevitable due to the evident duplication of communication functions and activities of its uncoordinated communication units.</p> <p>Factors that had negatively affected its over-all performance include the predominance of unskilled and inexperienced and misplaced communication production workers and insufficient policy and budgetary support to production operations. These had caused the inadequacy of communication facilities and other operational resources.</p> <p>The extension delivery system achieved minimal support. In fact, the extension worker-client ratio was estimated to be 1:162. This must have cause constraint in the technology transfer process and other extension services.</p> <p>Conclusion:</p>	
<p>Recommendations:</p> <ol style="list-style-type: none"> 1. Creation of a unified structure that will integrate all communication functions and services 2. More training programs to improve the manpower competence 3. The interpersonal delivery of information should be complemented with mass media channels. The relations with local and international fisheries research and development institutions as well as extension worker client ratio should be improved. The village level livelihood association should be strengthened. 4. Inclusion to the membership of the FIDC of the Minister of Information 5. Upgrading of the recruitment process 6. Provision of enough administrative staff and basic office, training and equipment to their provincial units 	

Figure 3. Reverse of the Note Sheet

Figures 2 and 3 have different boxes which are actually labels of different items considered important in the review of the literature. For one research report, only one sheet of paper is necessary. Both sides of the sheet are used.

Figure 4, on the other hand, requires more sheets. Each item to be described is highlighted in the box labeled DESCRIPTION OF. The item is described in detail in the space provided. The advantage of using this form is that when, for example, you want to compare, say, conceptual frameworks of different studies, all you need to do is put these sheets containing the conceptual frameworks side by side and make bull’s eye comparison. This technique is recommended when you are synthesizing many studies and you need to make quick comparisons among studies.

<i>Research Project Title:</i> SYNTHESIS OF SELECTED DEVCOM RESEARCH IN THE PHILIPPINES: SOME POLICY IMPLICATIONS IN AGRICULTURAL DEVELOPMENT PROGRAM IMPLEMENTATION	
<i>Bibliographic Citation:</i> Cardenas, Lizette DC. (1986). Acceptability of the Integrated Social Forestry Program (ISFP) Policies to Upland Farmers: a Case Study. MS Thesis. University of the Philippines Los Baños.	CDC Lib. No. M-105 Location: IDC Reading Room
<i>Type of Research:</i> Retrospective Case Analysis	<i>Research Category:</i> People Research
<i>Description of:</i> <i>Research Questions</i> <i>Objectives</i> <i>Conceptual Framework</i> <i>Locale of Study</i> <i>Respondents</i> <i>Sampling Procedure</i> <i>Variables</i> <i>Data Collection</i> <i>Data Analysis</i> <i>Findings</i> <i>Conclusions</i> <i>Recommendations</i>	<ol style="list-style-type: none"> 1. To describe the socio-cultural profile of ISFP participants and non-participants. 2. To determine the knowledge level of the participants regarding the ISFP policies. 3. To determine the attitude of participants and non-participants towards the ISFP policies. 4. To determine the source(s) of information of the ISFP participants and non-participants on forestry policies, particularly the ISFP policies. 5. To determine the source credibility as perceived by the ISFP participants and non-participants. 6. To determine the extension activities undertaken by the Bureau of Forest Development for the ISFP.

Figure 4. Modified Note Sheet

Other Helpful Rules of Thumb

1. *Cite those references that deal with every key variable.*
2. *Pay more attention to articles dealing with more than one variable. One-variable articles are less important.*
3. *If the literature is thin, say so. Cite references that deal with similar or conceptually related variables. These will become your suggestive literature.*
4. *Your headings should reflect your major variables. If your headings coincide with your topics in the first chapter, then you have a framework.*

In looking at the research literature, there are essential information you should not miss. The following questions may guide you in reviewing critically the related literature.

1. What is the research all about? What is the specific topic?
2. What are the independent and dependent variables? What are their respective values? Are there intervening variables? What are they? How did the researcher deal with the intervening variables?
3. Who were the respondents? How many? How were they selected?
4. What was the research design?
5. What kind of data analysis was employed? Was it appropriate?
6. What were the experimental treatments (if the article was a report of an experiment)? How were the respondents assigned to the experimental treatments? Were there any control groups.
7. What were the respondents made to do? Under what condition? Did they perform the required activity individually or in groups?
8. What were the major findings?

9. What were the researcher's conclusions? How did the researcher interpret his/her data? Was the interpretation appropriate and accurate?
10. How do these bits of information relate to other research reports on similar topics?

These questions should help you look at the literature more critically. Sometimes, you will be impressed by findings reported in journals but on closer look, however, the journal article may have been based on a research conducted in one university using all enrolled students in one freshman course. The research had a number of limitations, and it would not have been appropriate to make some generalizations out of the results.

In any case, if you are able to answer the questions listed earlier, you will be in a better position to interpret the literature because you have more information about the circumstances of the research. Consequently, your review of the literature will be more comprehensive and meaningful. Fewer relevant materials reviewed that answer the questions listed earlier will be more meaningful and helpful than a mere listing of findings of countless research reports.

Another point that must be emphasized here is the need to organize logically the presentation of the review. Simply listing the findings without relating them with one another is an impractical and useless way of presenting the materials. If two or more materials are related, in what way are they related? Are they related in terms of methodology? In other words, what are their similarities and differences? You must point out all these things so that the reader would have a better idea about the circumstances of the research. This is important when you are trying to interpret and understand the interpretation by the author of specific findings in a research report.

Finally, when you have reviewed the literature carefully, you must be able to show the flaws in the literature if there are any. These questions will help you establish the need for your study. What this means is that after reviewing the literature, you may find certain areas that need to be studied further, and this should at least be part of the reason why you are doing the study.

An example of a review of research reports is reproduced in Appendix A to demonstrate what has been described earlier. This article, titled "Prosocial Television Research," was published in *DEVCOM QUARTERLY*, Vol. 1, No. 2, pp. 4-18. To give you a better idea of how the literature ought to be treated, let us have a look at the first few paragraphs of the said literature review (Figure 5).

SAMPLE LITERATURE REVIEW	CORRESPONDING COMMENTS
<p>In recent years, social scientists have conducted a number of studies determining the effects of the behavior of both children and adults. These studies dealt with both positive and negative attitudes and behavior as a result of television viewing. In a number of laboratory and field experiments, researchers in North America have found that television programs designed to emphasize positive attitudes and behavior, aptly termed pro-social television, have tended to affect the viewer's attitudes and behavior positively.</p> <p>The Experiments</p> <p>Goldberg and Gorn (1974) attempted to determine whether or not television could change children's attitudes in a pro-social direction. The basic question was: would a series of inserts into "Sesame Street" produce the desired effects of creating more favorable attitudes towards children of several races in Canada and towards French-Canadian people and their culture?</p> <p>The researchers developed inserts that depicted other racial groups in a purely ethnic, non-integrated setting. They predicted that the inserts would be effective in producing a more favorable response to non-white children for two reasons. First, the integrated and non-integrated inserts were produced in an attractive</p>	<p><i>Here you have a general introduction to the research reports you are reviewing, indicating the scope and place of the research, as well as the variables studied. In other words, you are essentially describing the research problem or questions here.</i></p> <p><i>You are introducing the research problem here.</i></p> <p><i>Here, you're describing the procedures followed by the researchers, as well as describing (even briefly) the hypotheses of the study.</i></p>

<p>manner. Second, the inserts served to increase the exposure of the white children to other racial groups.</p> <p>In the final insert, a French-Canadian child speaking French appeared. The researchers observed that the children viewing the program paid more attention to what they saw than to what they heard. The French-Canadian child was liked very much by the children when he did not speak French. However, the children did not like him less either when they recognized him as a French-Canadian speaking an unfamiliar language. In the second insert, the children were exposed to a group of non-whites in an ethnic setting, and a mixed group interacting in a familiar setting. In both cases, the children preferred to play with non-whites rather than whites after exposure to the program.</p> <p>Goldberg and Gorn, therefore, concluded that minimal television exposure can produce very clear-cut short-term attitude change towards televised children of racial and ethnic groups.</p> <p>In the Goldberg-Gorn study, environmental factors were not considered. This was picked up by Friederick, Stein and Susman (1975) who conducted a laboratory experiment to determine the effects of pro-social television and environmental conditions on pre-school children. They were interested to find whether or not a television</p>	<p><i>Here you are explaining how the experiment was designed and undertaken, including general trends of the preliminary results.</i></p> <p><i>You are describing the conclusions arrived at by the researchers here.</i></p> <p><i>This portion serves to connect this review to the next review by establishing the relationship of the two studies, as a technique of providing continuity in your review discussion.</i></p>
---	--

program designed to enhance personal, social and emotional development had a positive effect on children's behavior, and what elements in the environment would contribute with exposure to television to produce the greatest positive effects.

The respondents were children, three to five years old, who were enrolled in Head Start Programs for Inner City Children. There were a total of 13 classrooms. Three classrooms were assigned to one of four experimental treatments except for the fourth treatment where there were four classrooms assigned. In the first treatment, the children were exposed to a neutral film plus irrelevant play materials in the classroom. The children in the second treatment were exposed to pro-social television plus irrelevant play materials in the classroom. The third group was exposed to pro-social television plus relevant play materials in the classroom. Finally, the fourth group was exposed to pro-social television plus a teacher who rehearsed the children on the content of the program they viewed.

Twenty episodes of the program "Mister Rogers' Neighborhood" or neutral film were used in the experiments under two classroom conditions, namely: high and low classroom structure. High classroom structure was operationalized as having harsh disciplinary procedures

You are describing the characteristics of the respondents of the second study here, as well as the details of the experiment.

Here, you are describing the specific materials and procedures used in the study, as well as description of the experimental setting, . . .

<p>and lack of warmth of the teacher, while the low classroom structure was operationalized as having high level of warmth from the teacher and non-punitive atmosphere.</p> <p>The variables that the researchers measured were positive social interaction with peers. Pro-social television with relevant play materials and a teacher had the highest effect upon the children under high classroom structure, while . . .</p>	<p><i>. . . and, finally, the results of the experiment.</i></p> <p><i>NOTE: Follow similar procedure in the rest of your literature review.</i></p> <p><i>When done with your review, you will need to make a statement that would synthesize all that you have reviewed. This helps in establishing that your study fills the gap that the studies you reviewed did not address.</i></p>
--	--

Figure 5. Sample review of the related literature and how it is written up



Chapter 4

Frameworks For Your Thesis

The Research Framework

The first kind of framework that you should be cleared about is what some would refer to as the research framework. This kind of framework does not have to be written specifically and included in your thesis proposal or manuscript. It is usually part of how you organize your thesis proposal or manuscript that indicates whether or not you have a research framework. It refers to the over-all structure and flow of your research proposal or manuscript. Let us explore this further.

The research framework may best be explained in the following manner.

1. When you formulate your thesis title, make sure that you present clearly the major variables you shall be working on in undertaking your thesis.
2. In the section where you are expected to describe your thesis (or research) problem, you must be able to show these variables and their relationships in the discussion

of the problem. You define more clearly your research problem by indicating the variables that you shall be working on.

3. The major variables that you shall be working on, and which you have indicated in your thesis title and research problem, must also be indicated in how you state your thesis objectives.
4. The same variables must also be indicated in how you formulate the hypotheses that you intend to test, if any.
5. These same variables must then be referred to, perhaps subtly, in how you ask questions in your research questionnaire or interview schedule.
6. Similarly, your study variables must be included in your data presentation, analysis, and interpretation so that they become part of your findings.
7. These findings that also contain your study variables must be expressed in your study conclusions, and finally, in your study recommendations.

In other words, there must be a one-on-one relationship between your study variables and the major sections of your thesis proposal or manuscript from the title down to the recommendations. When you have this structural flow of your thesis, then you have a clear thesis (research) framework. Let us show this in Figure 6.

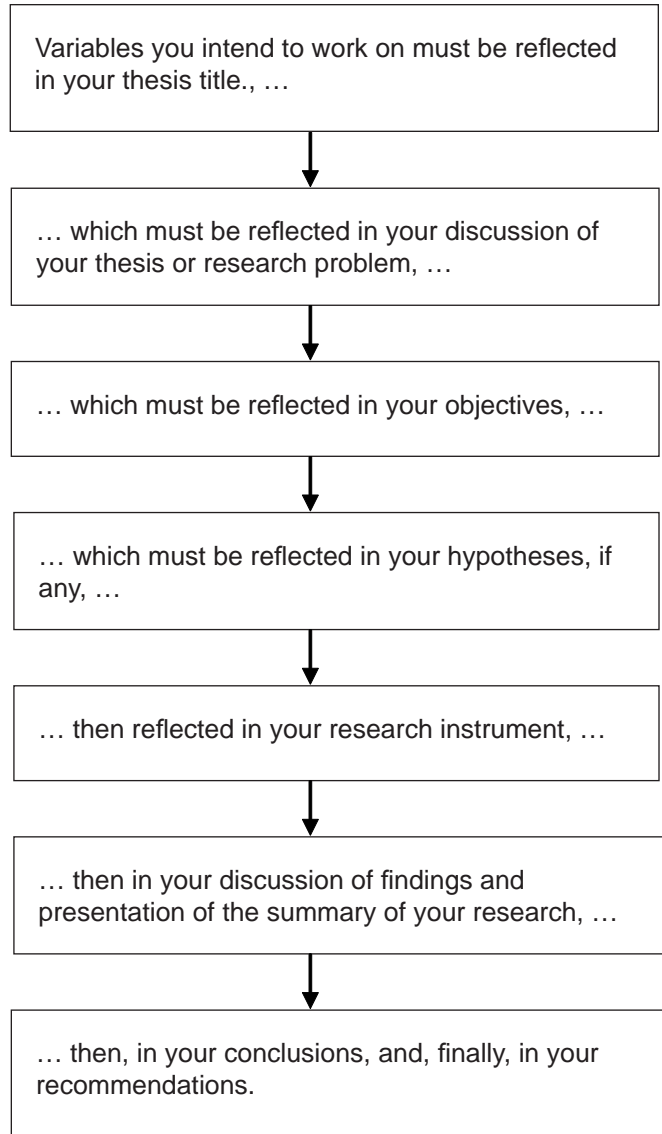

Figure 6. The structure of your thesis framework

In summary, if variables mentioned in your thesis title are reflected in the **research problem**, then in the **objectives of the study**, as well as in the **hypotheses** that you will test, they must also be in your findings, highlighted in your **conclusions**, and, finally, in your **recommendations**. Then you have a complete research framework.

Theoretical and Conceptual Frameworks

The theoretical framework presents the theory from which the research problem was derived (in the case of some experimental studies), or to which it is linked (in the case of some survey studies). In formulating the theoretical framework for the study, you may look at the various theories upon which you can base your study. In other words, this is a discussion of the theory which serves as the basis for the study.

For example in a study about color preferences of farmers, one fundamental theory upon which this study may be anchored is the Stimulus-Response Theory. This theory posits that for every stimulus there is a corresponding response (Suppes, 1977; Schmidt, nd). This relationship may be presented in Figure 7.

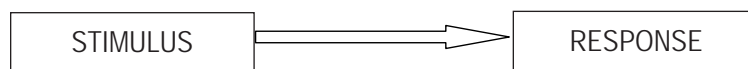

Figure 7. The stimulus-response theory

Another example would be a study on climate change in the Philippines. If you push to the limits your analysis, you will eventually end up basing your study on general systems theory. A system is defined as an entity whose parts, with their own properties, interact with one another in order to achieve an over-all goal (Hall and Fagen, 1968). The theoretical framework is an extensive discussion of the theory upon which your thesis is anchored.

The conceptual framework, on the other hand, presents the relationship between the specific concepts that may be studied. The concepts used at this level should be derived from the concepts used in the theoretical framework. They should be more concrete, however. Suppose that you are going to do a study on the relationship between membership in a social network and the performance of organizational activities by members of such social network, you could, theoretically, apply the S-R theory. Let us operationalize this through the conceptual framework as shown in Figure 8.

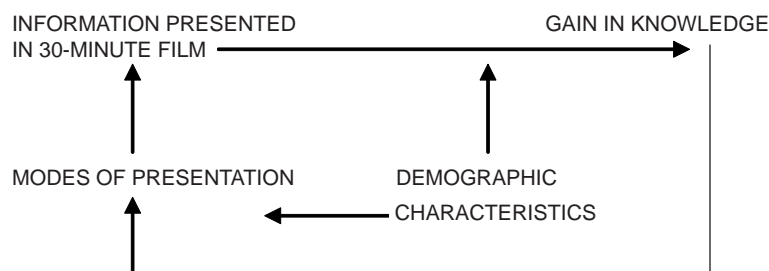

Figure 8. Hypothetical conceptual framework

The conceptual framework establishes the hypotheses (discussed at length in Chapter I) that you intend to test in your thesis. Another way of presenting the conceptual framework shown in Figure 8 is shown in Figure 9.

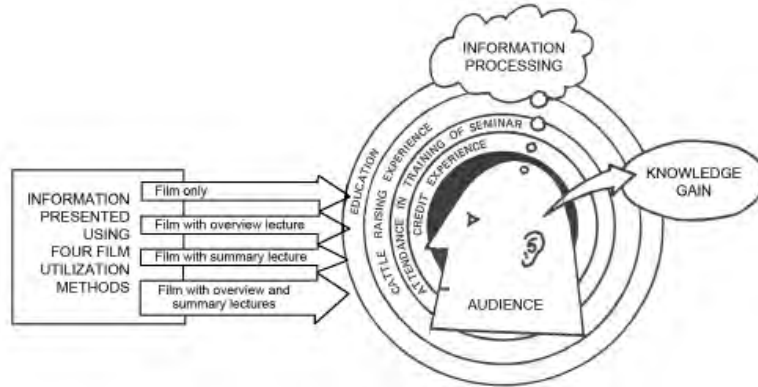

Figure 9. A model showing stages of communicating information using four film utilization methods.

The relationship between the theoretical framework and the conceptual framework may be shown in Figure 10, in the form of a matrix.

LEVEL	INDEPENDENT VARIABLE	INTERVENING VARIABLE	DEPENDENT VARIABLE
Theoretical	Stimulus		Response
Conceptual	30-minute film	Mental set of audience; motivation, etc.	Knowledge Gain

Figure 10. Theoretical/conceptual framework matrix

The Operational Framework

Many researchers, including experienced thesis advisers, normally look for an operational framework for proposed research projects or theses, so let's have a quick look at this here. What do we mean by the operational framework? If the research framework refers to the one-on-one relationship between your research problem, objectives, hypotheses, procedures, conclusions and recommendations, and your theoretical framework refers to the theory upon which your study is anchored, then we can say that the operational framework would substantially refer to the operational procedures and the manner in which you would manage the implementation of your research according to a model of variable relationships that you want to test (Wamsler, 2009).

This volume takes the position that the operational framework is a further clarification of the theoretical-conceptual continuum discussed earlier. Let's look at this in operational terms. Suppose that you have been studying the literature associated with your research problem, and, in the process, you have discovered that models that appear to differ have been used in the explanation of the relationship of the variables that you want to study, what you would logically do is to do a comparative analysis of these models. As a result of your comparative analysis, you would most likely construct a composite model that integrates the components and elements that may be common to all the models you have reviewed. On the basis of this composite model, you would likely construct guidelines in implementing and assessing the said composite model (which is really doing field testing). As a result, you would come up with suggested possibilities about implementing the composite model and a set of indicators of success or applicability. This entire process may be referred to as the operational framework of your study.

In short, your operational framework enables you to present a set of indicators that would help you integrate what you need to include in the assessment. The operational framework also enables you to do a benchmark assessment of the variables you want to study in your research. Further, it enables you to provide the output indicators that you expect from the research. In other words, it is an operationalization, or more simply a step-by-step procedure that you may follow in doing your research.

The beauty of the operational framework is that you are the one designing a rigorous procedure that considers the specific variables and their relationships that you want to study. In other words, the operational framework is a customized procedure that enables you to do exactly what you need to do with all the attendant rigors of *scientific work*.

Chapter 5

The Methodology

Chapter of Your Thesis

The chapter titled “Methodology” explains in detail the over-all procedure you will follow in conducting your thesis. It includes detailed discussions of the design of the research, explanation of variables you will study, the description of respondents from whom you shall collect your data, sampling procedures, description of research instruments you will use in collecting your data, steps you will follow in collecting data, and the methods and tools you will use to analyze your data. Sometimes, this is referred to as “Methods and Procedures.”

When, after reading the methodology, one is able to explain what is going to be done, why it is going to be done, and how it is going to be done, then the methodology is well-developed and understandable.

The Research Design

The research design is the plan, structure, and strategy of the investigation. The plan is the over-all scheme to be followed in conducting the research. The structure

is the more specific outline of how the variables are operationalized. The strategy is a description of details such as methods to be employed in collecting and analyzing data. Put together, the plan, structure, and strategy imply how the research objectives will be tackled. The research design “provides a framework for the collection and analysis of data and subsequently indicates which research methods are appropriate” (Walliman, 2006, pp. 42-49). Yin (2006) puts it more in practical terms when he said, “colloquially, a research design is an action plan for getting from here to there, where ‘here’ may be defined as the initial set of questions to be answered, and ‘there’ is some set of conclusions (answers) about these questions” (p. 30). In-between the “here” and “there,” there may be major events, such as specific techniques of collecting and analyzing data.

In the past, research designs have been lumped into four categories referred to as experiments, quasi-experiments, surveys, and participant observation (Kidder, 1981). In recent years, however, new designs such as action research designs, correlational designs, survey designs, ethnographic designs, to name some, have been developed and have become common among social science and education researchers (Creswell, 2002; Leedy & Ormrod, 2005).

Experimental designs

Experiments are conducted to answer questions about causes and effects. The basic requirements for experiments are: a) random assignment of respondents or research participants, b) treatment and no-treatment groups, and c) observations after the treatment. In describing the different experimental designs, we shall use the following notations:

- X = stands for an experimental treatment, or an independent variable, or a cause
- O = stands for an observation, or a dependent variable, or an effect
- R = means that the respondents have been randomly assigned to the different treatment or non-treatment groups or conditions

Design 1. Randomized two-group design. Randomly assign respondents to the experimental group (X) and the no-treatment group (No-X). The condition here is that the two groups (X and No-X) must have equivalent n or sample sizes before the treatment so that you can attribute any post-treatment effects to the experimental treatment.

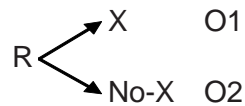

Design 2. Before-after two-group design. This adds a set of pre-treatment observations. Hence, you will first conduct a pre-test, introduce the treatment and then conduct a post-test. This design enables you to determine the effect of the treatment by establishing the difference between the post-test and the pre-test. However, it is also possible that the post-test results may be abnormally high because the respondents may have been forewarned by the pre-test. In other words, pre-tests may sensitize the respondents to the purpose of the experiment.

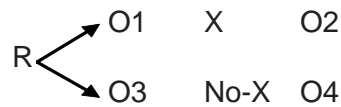

Design 3. Solomon four-group design. The design combines Designs 1 and 2. It tries to eliminate the disadvantages of Design 2, which is the possibility that pre-tests would sensitize the respondents and combine the strengths of both designs. This design is expensive because you need four groups of respondents. In addition to the treatment and no-treatment groups, you also need pre-tested and non-pre-tested groups.

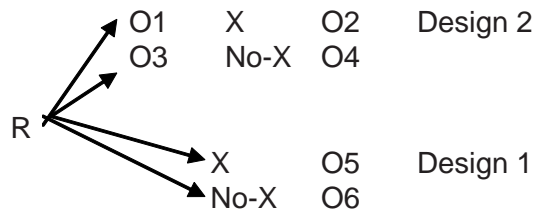

This design combines the strength of Design 1 (which is the absence of interference from pre-testing effects) and the strength of Design 2 (which is the ability to provide greater precision measurement of treatment effects).

Design 4 Factorial design. Two or more independent variables or factors are presented in combination. The basic structure of the factorial design is as follows:

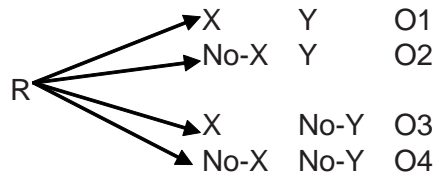

where: X = one independent variable
 Y = another independent variable

This design may also be presented in a matrix, which is called a 2x2 factorial design. Let us consider the first independent variable (Factor X) as the student's gender (sex) with two values (male and female), and a second independent variable (Factor Y) as the student's behavior, also with two values (active and passive). These independent variables and their respective values may be presented in a 2x2 factorial design matrix (Figure 11).

Factor X (Student's Gender)	Factor Y (Student's Behavior)	
	Active	Passive
Male	Active-Male	Passive-Male
Female	Active-Female	Passive-Female

Figure 11. Sample factorial design matrix

The 2x2 factorial design matrix means that there are two factors or independent variables, each with two values. This gives you a total of four conditions, namely: active-male, active-female, passive-male and passive-female.

Quasi-experimental designs

These are research designs that lack random assignment of respondents to experimental treatments so that comparison between treatments has to be done with groups that are not equivalent.

Interrupted time-series design. This design enables you to make a series of observations prior to introducing a treatment. After introducing the treatment, you can make as many observations as the previous observations you have made, then compare the two sets of observations. This may also be called a longitudinal design.

O1 O2 O3 O4 O5 X O6 O7 O8 O9 O10

Regression-discontinuity design. This is essentially a “cross-sectional design” because it deals with the effects of treatments across many groups of respondents. To the time-series design, the regression-discontinuity design adds observations from different groups all at one time.

Group 1	O1
.....	
Group 2	O2
.....	
Group 3	O3
.....	
Group 4	O4
.....	

The dotted lines indicate that the respondents are not randomly assigned to the groups.

Pretest-posttest non-equivalent control group design. This design involves two different groups, one with a pretest, treatment and a posttest, and the other two sets of observations (one representing the pretest and the other the posttest). Respondents are not randomly assigned to the groups.

Group 1	O1	X	O3
.....			
Group 2	O2		O4

The comparison of the two groups is not based on random assignment but on the pre-existing or pre-selected groups, which were chosen because they were similar but not equivalent.

The quasi-experiment is usually the second best choice if you are unable to do a true experiment. By true experiment, it is meant that you can randomly assign respondents to treatment groups.

Survey research design

The survey research design is a strategy that enables you to study “naturally occurring phenomena.” It enables you to answer questions about the distribution of and relationships among characteristics of people as they exist in their natural setting (Mitchell & Jolley, 2004; Alreck and Settle, 1985). In a survey research, you collect data from at least a part of the population as basis for assessing the incidence, distribution, and interrelations of phenomena as they occur in the lives of people. You do surveys if you intend to describe trends, determine opinions, identify characteristics of groups, understand beliefs and attitudes, identify practices, and evaluate programs (Creswell, 2002).

According to Alreck and Settle (1985), there are four basic survey designs.

1. *Cross-sectional survey.* In this design, you collect data at one point in time from a sample selected to describe a population at that time.
2. *Longitudinal survey.* This is a collection of data over time. Sometimes, this is called time-series study. There are three types of this design. The first is trend study, which deals with describing the variables as they exist or change over time. The second type is cohort study. This deals with the same specific population each time data are collected even if sample may be different. For example, you may conduct a survey of graduate students in development communication five years hence. Another way of doing it is to survey 25-year old students today, and do another survey of 30-year old students five years from now. A third longitudinal design refers to the panel study. You collect data over time from the same sample. For example, you may conduct a poll now to establish preference of voters in a congressional district during an election period. Then,

conduct a similar survey of the same voters a couple of weeks later. This way, you are able to establish changing preferences among voters.

3. *Contextual study.* You collect data about some portions of an individual's environment, and use this set of data to describe the individual. This is actually an examination of the context within which the individual is existing. This may best be described by the dictum: "tell me who your friends are and I'll tell you who you are."
4. *Sociometric study.* This is a method of determining human interrelationships. Using the basic survey format, you can determine who is closest to whom by simply asking each individual to name his/her close friends. Based on this information, you can establish a social network among people in a group.

Survey research has very important ethical issues that you have to contend with. There are three such issues.

1. *Voluntary participation.* The survey is an intrusion into the lives of people. Therefore, their participation must be voluntary.
2. *No harm to respondents.* Never harm respondents who volunteered to participate in your survey. Harm may not necessarily be physical. Harm may be the result of revealing information that may hurt the person emotionally or endanger his/her life.
3. *Anonymity and confidentiality.* These twin issues are not the same, but they are both very important in survey research. You may have successfully satisfied the requirements of anonymity if, upon reading your report, a reader is unable to relate a given response to the condition wherein a respondent should not be identified and his/her response not publicly imputed to him/her.

In other words, you must assure the respondent that any information that he/she will provide will be treated confidentially.

Participant observation

Participant observation is different from the designs previously discussed. According to Bogdan (1972), participant observation is “characterized by a prolonged period of intense social interaction between the researcher and the respondent, in the milieu of the latter, during which time, data in the form of field notes, are unobtrusively and systematically collected” and recorded.

As a participant observer, you take part in all the activities under all conditions you wish to understand. You act as one of the members of the group or society, share your experiences with your respondents or informants, and maintain a prolonged contact in the situation. These activities allow you to “view the dynamics of conflict and change, and thus, see organizations, relationships and group and individual definitions in process” (Bogdan, 1972). The purpose of participant observation is to develop an understanding of complex social settings and relationships. Normally, as a participant observer, you carry out your observations in organizational settings where you have no direct personal interest. You devote your time carrying out your observation while you are in the setting. You have to be systematic in your observations, keep detailed notes, record what you observe, and you must have had training in the craft of observation.

There are standard arguments against participant observation. For instance, participant observation revolves around the observer’s bias or selective perception, and you may analyze non-representative data, which may pose some reliability problems. Further, the presence of the participant observer can influence the behavior of the

respondent. Given these, the three broad questions that confront the participant observer are:

1. What should be observed?
2. How should observation be recorded?
3. What relationships should exist between the observer and the observed, and how can such relationships be established?

Content analysis

Content analysis (Carney, 1972) is a “technique for making inferences by objectively and systematically identifying specified characteristics of language.” List (2005) defines content analysis as a “method of summarizing any form of content by counting various aspects of the content.” In the field of communication, it was Bernard Berelson’s pioneering work that started the application of content analysis as a “technique for the objective, systematic, and quantitative description of manifest content of communications” (Berelson, 1952 as cited by List, 2005). List (2005) highlights the fact that by employing content analysis as a method of research, you may be able to reveal differences in communication content, identify intentions, focus, or communication trends of an individual or group or institution, describe attitudinal and behavioral responses to communications, and determine psychological or emotional state of persons or groups.

Williamson et al. (1977) said that researchers using content analysis are objective in their evaluation of communications content because content analysis is a systematic procedure that provides quantitative description of communications. They point out, however, that while this methodology may allow researchers to “characterize efficiently a large number of materials, it also has the risk of missing the over-all sense

of a body of communication if you do no more than offer statistical summaries of their content.

Researchers using content analysis usually investigate thematic content of the communication using the following goals:

1. To make inferences about the values, sentiments, intentions or ideologies of the sources or authors of the communications;
2. To infer group or societal values through the content of communications; and
3. To evaluate the effects of communications on the audiences they reach.

Delphi

According to Linstone and Turoff (1975), Delphi may be characterized as a “method of structuring a group communication process so that the process is effective in allowing a group of individuals, as a whole, to deal with a complex problem.” The Delphi technique was really a result of defense research in the U.S. in the early 1960s. At that time, the U.S. Air Force sponsored a study conducted by Rand Corporation to “obtain the most reliable consensus of opinion of a group of experts ... through a series of intensive questionnaires interspersed with controlled opinion feedback.” This project was called Project Delphi.

The Delphi technique has become a common methodology for futuristic research. Here is how Delphi works. Suppose that you would be interested to know what will be the five most significant events that will bring the Philippines right into the forefront of the digital society during the next five years, you can use the Delphi technique.

1. Select, say, 50 communications experts and ask them, through a questionnaire, the following question: “what do you think will be the five most significant events that will bring the Philippines right into the heart of the digital society five years from now? Please rank-order them accordingly.”
2. Upon getting the responses back, you put together all responses and rank the first five answers. Then, return to the respondents the list of the top five events based on their rankings. Ask them if they agree with the ranking. If they do not, ask them to re-rank the five events and return their responses to you.
3. Go through the process again of making another ranking based on the respondents’ answers. This process may go on until a consensus is reached (perhaps about five rounds). A consensus shall have been deemed reached if there would be no more alterations in the rankings.
4. The final listing of events shall indicate that those items included in the last ranking would most likely be the significant events that would bring the Philippines into the heart of the digital society in five years’ time.

The Delphi technique is an interesting forecasting methodology, but it is laborious and time consuming.

Problematique analysis

Problematique analysis is a naturalistic methodology for discovering the structure of problems that exist in social systems. The basic purpose of this methodology is to identify the causes of the problem rather than the solutions.

In the process of employing problematique analysis, you identify the factors that influence the system, show the hierarchical relationships of these factors, and trace the root causes of the problems in the system (Librero, 1981 & 1982).

A full-blown discussion of problematique analysis is presented in Appendix D.

Describing the Variables of the Study

According to Kerlinger (1973), a variable is a “symbol to which numerals or values are assigned.” For example, “sex” is a variable and it has two values, namely: “male” and “female. There are two common ways of categorizing variables: independent and dependent variables, and intervening variables.

Independent and dependent variables. The independent variable is the presumed cause, while the dependent variable is the presumed effect in experiments. The independent variable is that which you can manipulate. In non-experimental research, the independent variable is that which has presumably been “manipulated” before you took it. In a study to determine the effect of a television program on the behavior of children, the television program is the independent variable, while the behavior of children is the dependent variable.

Intervening variable. The term intervening variable is used to label internal and unobservable psychological processes that account for behavior (Kerlinger, 1973). The intervening variables are useful and powerful, and even indispensable in modern research data analysis. Understanding how the intervening variables operate will help you more accurately interpret your data. An example of an intervening variable, according to Kerlinger (1973), is hostility, which presumably accounts for aggressive acts.

It is always necessary that you define the variables of your study. What composes the independent variable? A major reason why you need to accurately label your variables is that this will help you determine which ones are going to be manipulated and which ones will be observed.

Describing the Respondents of the Study

In the past, social science researchers used the term “subject” to refer to individuals who were selected to be sources of information and data. However, in the 1960s, the U.S. Federal Government introduced policies that prescribed certain nomenclatures and conditionalities in the conduct of research that involved human individuals. For instance, it became unethical to call people who were to provide information to researchers “subjects”, but instead, should be called “respondents.” The term was apt because people were supposed to respond to research instructions and questions rather than simply be passive recipients of research procedures. Under this new policy, it also became unethical to subject humans to experimentation, unless they were completely aware that they were participating in an experiment on a voluntary basis, provided that they were not harmed in any way. Today, the term “respondents” refers to human participants in a research activity, while the term “subjects” is used to refer to animals that are used in research conducted under laboratory conditions.

A very common error among thesis students is incorrect and incomplete description of respondents in their studies. For example, if your study deals with market vendors in Divisoria, it is not enough simply to call them “market vendors,” but perhaps “fruit vendors.” In other words, this section of the research proposal discusses in detail the characteristics of the respondents of the study. Include

also description of the population that they represent, their geographical or even socioeconomic location, as well as the rationale for choosing them as respondents for the study.

A significant additional reminder at this point is the use of appropriate and accurate reference to your research participants. In the social science research parlance, individual respondents (referring to participants in surveys), or informants (in the case of focused interviews), or discussants (in the case of focused group discussions) are usually referred to as “units of analysis.” However, the unit of analysis is not always the individual. Other units of analysis may be institutions, social groups, cultural groups, communities, media organizations, specific media programs like television shows or radio programs, and the like. Depending on the nature of your study, you are pretty much free to determine your units of analysis depending on the nature of your study.

Sampling Techniques

A sample is part of the population which is observed in order to make inferences about the whole population (Manheim, 1977). You use sampling when your research design requires that you collect information from or about a population, which is large or so widely scattered as to make it impractical to observe all the individuals in the population. A sample reflects the characteristics of the population.

Four factors that you should take into consideration when selecting your sample and the size of your sample are the following:

1. *Homogeneity.* Take samples from a homogenous population. Samples taken from a heterogeneous population will not be representative of the population, and therefore, cannot be inferred from.

2. *Size of population.* If the population is large, you need a sample. However, you do not need a sample if the population is small and can be handled if you include all the individuals in the population. Including all the individuals in the population is also called total enumeration.
3. *Cost.* Your choice of sampling method should be based also on the cost of adopting such method without necessarily sacrificing representativeness of the population being considered.
4. *Precision.* If you have to achieve precision, you will need a larger sample because the larger the sample, the more precise the results will be.

Probability sampling

According to Domingo (1954), probability sampling is a sampling process where each individual is drawn or selected with known probability. Parel et al. (1966) consider a sample to be probability sample when every individual in the population is given a non-zero chance of being chosen for the sample. There are six techniques under this sampling method.

1. *Random sampling.* Also called simple random sampling, this technique is a way of selecting n individuals out of N such that everyone has an equal chance of being selected. Sample individuals are selected at points entirely at random within the population. This technique is suitable for homogeneous populations.
2. *Systematic random sampling.* This technique starts by numbering consecutively all individuals in the population. The first sample is selected through a simple random process, then the succeeding samples are

chosen at pre-established intervals. To determine the appropriate interval, divide N by the desired number of sample.

3. *Stratified sampling.* This technique is applicable when the population is not homogeneous wherein the random sample may not be representative of the population. When you do stratified sampling, divide the population into homogeneous groups called strata, then draw samples either by simple random sampling or stratified sampling from each of the formed strata. For precise results, the total number of the desired sample may be allocated equally among the strata. This technique prevents any chance concentration of sample units in one part of the field because they are well distributed. For example, suppose that you would like to take a sample of students at the University of the Philippines Los Baños using the stratified sampling technique. The stratification of the student population has already been made for you. The strata are: “freshmen,” “sophomore,” “junior,” and “senior.” What do you do to select your sample from each of these groups of students to insure that you get a cross-section of the UPLB studentry? If you select your sample by simple random selection, there is chance that you will end up with a sample composed more of seniors or juniors rather than representative groups of students in all classifications.
4. *Simple cluster sampling.* This is a one-stage sampling technique wherein the population is grouped into clusters or small units composed of population elements. A number of these population clusters is chosen either by simple random sampling or by systematic random sampling.

5. *Strip sampling.* Under this technique, you divide the area to be sampled into narrow strips. Then, select a number of strips at random either by complete randomization or with some degree of stratification. Sometimes you may consider only a part of the strip as a sample unit.
6. *Multi-stage sampling.* This technique is commonly used when there is no detailed or actual listing of individuals. You do sampling stages, which means that you group the population elements into a hierarchy of individuals or units, and sampling is done successively.

For example, you want to get a representative sample of all farmers in the country? This is how you should do it:

- a. From all the 12 regions of the country, randomly select, let's say, three provinces from each region, which gives you three sample provinces;
- b. from each of the three provinces, you may decide to randomly select five municipalities, which gives you 15 sample municipalities;
- c. from each of the five municipalities, you may decide to randomly select five barangays, which will give you 65 sample barangays.
- d. from each of the 65 barangays, you may decide to randomly select 50 farmers, which should give you a total of 3,250 farmers who would constitute your sample for the study.

Non-probability sampling

According to Yamane (1967), this method is a process whereby probabilities cannot be assigned objectively to individuals in the population. Simply, not all the individuals in the population are given a non-zero chance of being included in the sample. In fact, some individuals in the population may be deliberately ignored.

Judgment sampling. This is a process whereby you select a representative sample according to your subjective judgment. Since personal bias is usually a factor in the selection of sample, there is no objective way of evaluating the results of this technique. This sampling technique may be appropriate when you have to make judgment about an individual's potential as a source of information.

Quota sampling. This is simply a variation of judgment sampling, which provides more explicit instructions on who to select. A definite quota must be filled. The quota is determined to a certain extent by the characteristics of the population so that the quota sample will be representative of the population. This is commonly used in opinion research, where interviewers are just given specific quotas or number of respondents to interview. This technique is very economical and simple, but it must be used with caution as it allows for a wide latitude of interviewer's choices which may result in biases. The assumption here, however, is that field investigators have high integrity and they have undergone thorough training.

Accidental sampling. This technique is very simple in that whoever happens to be there at the time of the interview is interviewed and becomes part of the sample. This is normally done in spot surveys for audience studies, for example.

Determining your sample size

On top of the basic sampling techniques that are commonly used, you can introduce a system where you can insure that the final sample of your study is really representative of the population comprised of individuals that may come in clusters or groups. This is called proportional sampling and there is a simple formula that would enable you to arrive at a complete sample that is representative of the segments of the population.

For instance, you want to obtain a sample sufficiently representative of the barangays or villages in a town. You know that the barangays differ in total number of individuals living in them. So you decide that those with larger population should be represented by more respondents. How then would you determine the number of respondents coming from each village?

Apply the following formula:

$$n_1 = \frac{N_1}{N} n$$

where: n_1 = desired sample size for the barangay
 N_1 = population of the barangay
 N = population of the town
 n = total sample for the study

The Research Instrument

Most social science researchers make use of two types of research instruments (the tools to gather data). These are the questionnaire, and the interview schedule.

The questionnaire

The questionnaire is a set of questions arranged in sequence and designed to be self-administered. The instructions in the questionnaire are directed at the respondent. There are a number of advantages of using the questionnaire.

1. It is a less expensive procedure. It requires less skill to administer and can be administered to a large number of respondents simultaneously.
2. It ensures some amount of uniformity from one measurement situation to another because of its standardized wording, order of questions, and instructions for recording responses.
3. In completing questionnaires, respondents may have confidence in their anonymity so that they feel freer to express their views.
4. A questionnaire puts less pressure on the respondents to provide an immediate response.

As a general rule, you may use the questionnaire if your respondents are literate, easily contacted, and clearly motivated to respond. If one of these conditions is not fulfilled, it would be better to collect data through interviews.

Characteristics of a "Good" Questionnaire. According to Best (1971), the characteristics of "good" questionnaire are:

1. It deals with a significant topic that the respondent will recognize as important enough to warrant spending his/her time on.
2. It seeks only the information that cannot be obtained from other sources.
3. It should be only long enough to get essential data.

4. It must be attractive, neat, and clean.
5. All instructions or directions must be clear and complete. They must be worded simply, and categories should provide an opportunity for easy, accurate, and unambiguous responses.
6. Questions should be as objective as possible, avoiding suggestions that tend to lead to the responses desired.
7. Questions must be presented in good psychological order, from general to specific responses. This will enable the respondent to organize his/her own thoughts so he/she can give logical and objective responses. If possible, annoying or embarrassing questions must be avoided.
8. The questionnaire format should be so constructed such that data will easily be tabulated and interpreted. If a mechanical tabulating machine is used, it is important that all questions and answers have codes.

Information Obtained from a Questionnaire. According to Dillman (1978), there are four types of information that you can expect to generate from your questionnaire. It is important that you are able to understand the differences among these types of information.

1. *Attitude.* Attitudes refer to what people say they want. They describe how people feel about something. Attitude questions must show whether the respondent has a positive or negative feeling about an attitude object. You can ask attitude questions in a variety of ways. Following are examples:

A. Should commercial logging operations be banned?

- 1 NO
- 2 YES

B. In general, how do you feel about a total ban on commercial logging in the Philippines?

- 1 STRONGLY OPPOSE
- 2 MILDLY OPPOSE
- 3 NEITHER OPPOSE NOR FAVOR
- 4 MILDLY FAVOR
- 5 STRONGLY FAVOR

C. Do you tend to agree or disagree with this statement?
“Anyone who wants to cut logs for profit should be allowed to do so.”

- 1 AGREE
- 2 DISAGREE

2. *Belief.* This is what people think. They are assessments of what a person thinks as true or false. Goodness and badness are not implied in beliefs, only what one thinks does or does not exist. Belief questions are designed to elicit one’s perceptions of past, present, and future reality. You can ask belief questions as follows:

A. Is this statement true or false? “Last year, there were more illegal commercial logging operations than legal ones on Mt. Makiling.”

- 1 TRUE
- 2 FALSE

B. In your opinion, would banning commercial logging prevent someone from cutting logs for his/her own personal use?

- 1 ALWAYS YES
- 2 USUALLY YES
- 3 SOMETIMES
- 4 ALMOST NEVER
- 5 NEVER

C. Do you think that banning commercial logging in the Philippines will actually decrease the rate of deforestation?

- 1 NO
- 2 YES

3. *Behavior.* This is what people do. Dillman (1978) points out that, strictly speaking, behavior questions elicit people's beliefs about their behavior. However, if you ask someone to describe his/her view or view something he/she has experienced rather than describe his/her own behavior, then you are asking for distinct information on his/her behavior. A behavior question may concern what one has done in the past, what he/she is now doing, or what he/she intends to do. Here are examples:

A. Have you even been involved in commercial logging?

- 1 NO
- 2 YES

B. Are you currently holding a logging permit?

- 1 NO
- 2 YES

C. Do you think you will engage in commercial logging on Mt. Makiling in the near future?

- 1 No
- 2 PROBABLY NO
- 3 PROBABLY YES
- 4 YES

4. *Attribute.* This refers to what people are. It normally refers to personal or demographic characteristics. You tend to look at attributes as something you possess rather than something you do. You gather information on personal attributes because you always want to find how other types of information (attitude, belief, and behavior) differ for people with different attributes. The following are examples of attribute questions:

A. Are you presently married?

- ___ 1 NO
___ 2 YES

B. What is your present age?

___ YEARS

C. How many children do you have?

___ NUMBER

Structuring Your Questions. There are three basic types of structures of questions (Dillman, 1978). They are as follows:

1. *Open ended.* In open-ended questions, answer choices are not provided. Therefore, the respondent must “create” his/her answer to the question. Examples:

- A. What should be done to improve this university? (attitude)
B. In your opinion, what is the biggest barrier to getting students to use the learning center? (belief)
C. What student organization have you joined since your first semester in this university? (behavior)
D. In what province is your residence located? (attribute)

2. *Close-ended with ordered choices.* For this kind of close-ended question, answer choices are provided and arranged in an order that the respondents can not change. Here are examples:

A. Who would be most, second, and third influential in deciding whether this university puts up a university bookstore? (attitude)

(Put appropriate number on each blank space provided.)

- | | |
|---|----------------------|
| <input type="checkbox"/> 1. MOST INFLUENTIAL | 1 CHANCELLOR |
| <input type="checkbox"/> 2. SECOND MOST INFLUENTIAL | 2 PUBLISHING COMPANY |
| <input type="checkbox"/> 3. THIRD MOST INFLUENTIAL | 3 STUDENT COINCIL |
| | 4 FACULTY COUNCIL |
| | 5 FRATERNITIES |
| | 6 GENERAL PUBLIC |

B. Which one of the following do you think is most responsible for high tuition fees? (belief)

- | | |
|--|----------------------------------|
| <input type="checkbox"/> MOST RESPONSIBLE | 1. SALARY INCREASES FOR FACULTY |
| <input type="checkbox"/> SECOND MOST RESPONSIBLE | 2. HIGHER PROFITS FOR UNIVERSITY |
| <input type="checkbox"/> THIRD MOST RESPONSIBLE | 3. LOW BUDGET ALLOCATION |
| | 4. TOO MUCH GOVERNMENT SPENDING |
| | 5. LOW ENROLLMENT |

C. Which top three among the listed university facilities you spent most of your time last week? (behavior)

- | | |
|---------------------------------|---------------------------------|
| <input type="checkbox"/> FIRST | 1. WRITING THESIS OUTLINE |
| <input type="checkbox"/> SECOND | 2. WATCHING TELEVISION |
| <input type="checkbox"/> THIRD | 3. PLAYING BILLIARDS |
| | 4. PARTICIPATING IN SPORTSFESTS |
| | 5. VISITING FRIENDS |

D. Which of the following income brackets does your family belong? (attribute)

- 1 P30,000/YEAR AND BELOW
- 2 P31,000 – P50,000/YEAR
- 3 P51,000 – P100,000/YEAR
- 4 P101,000 – P150,000/YEAR
- 5 P151,000 AND OVER

3. *Close-ended without ordered choices.* In this kind of close-ended question, answer choices are also provided, but they are not pre-arranged in any order that the respondents simply selects from. In this situation, the respondent must choose that one best reflects his/her situation. Here are examples:

A. Who do you think would be the most influential individual or group in deciding whether or not this university should put up a bookstore? (Attitude) Please just tick one.

- CHANCELLOR
- PUBLISHING COMPANY
- STUDENT COUNCIL
- FACULTY COUNCIL
- FRATERNITIES
- GENERAL PUBLIC

B. Which one of the following do you think is most responsible for high tuition fees in this university? (Belief) Please tick just one.

- FACULTY DEMAND FOR SALARY INCRFEASES
- UNIVERSITY DEMAND FOR HIGHER PROFITS
- LOW BUDGET ALLOCATION FROM GOVERNMENT
- TOO MUCH SPENDING BY THE UNIVERSITY
- LOW ENROLLMENT

C. Which of the following have you spent most of your time last week? (Behavior) Please tick just one.

- WRITING MY THESIS OUTLINE
- WATCHING CABLE TELEVISION
- PLAYING BILLIARDS
- PARTICIPATING IN SPORTSFEST
- VISITING FRIENDS

D. What brand of wrist watch do you wear? (Attribute) Please tick just one.

- SWATCH
- GUESS
- TUGARIS
- CITIZEN
- DIVISORIA

4. *Partially close-ended.* This question provides a compromise. Answer options are provided, but the respondent is also given the opportunity to create his/her own response to the question. Here are examples:

A. Which of the following areas of expenditure do you want to have the highest priority for improvement in this university? (Attitude)

- 1 STREETS
- 2 CLASSROOMS
- 3 COMFORT ROOMS
- 4 LIBRARY
- 5 OTHERS (SPECIFY) _____

B. For what reasons did you transfer to this university? (Belief)

- 1 HIGHER ACADEMIC STANDARDS
- 2 LOWER SCHOOL FEES
- 3 CLOSER TO MY RESIDENCE
- 4 AVAILABILITY OF SCHOLARSHIPS
- 5 OTHERS (SPECIFY) _____

C. Which of these university facilities do you most frequently use? (Behavior)

- 1 LIBRARY
- 2 TENNIS COURT
- 3 COMPUTER CENTER
- 4 SWIMMING POOL
- 5 OTHERS (SPECIFY) _____

D. What do you consider yourself to be? (Attribute)

- 1 LEADER
- 2 FOLLOWER
- 3 IMPLEMENTOR
- 4 PLANNER
- 5 OTHERS (SPECIFY) _____

In summary, any one of these four structures may be most appropriate for a particular question depending on your plans for using the responses. For example, take the case of the hypothetical selection of the chancellor of the University of the Philippines Los Baños. You can formulate the following questions according to the structure you want, as follows:

Open ended:

Who do you like to see appointed Chancellor of UPLB?

Close-ended with ordered choices:

How well do you think each of these candidates would perform if elected Chancellor?

1. ERNIE	POOR	GOOD	EXCELLENT
2. TONY	POOR	GOOD	EXCELLENT
3. JULIET	POOR	GOOD	EXCELLENT
4. JULIAN	POOR	GOOD	EXCELLENT
5. GABBY	POOR	GOOD	EXCELLENT

Close-ended with unordered choices:

Which of these five candidates would you most like to be elected as Chancellor? (Circle the number of your answer.)

1. ERNIE
2. TONY
3. JULIET
4. JULIANM
5. GABBY

Partially close-ended:

*Who would you like to be elected as Chancellor?
(Circle number of your answer.)*

1. ERNIE
2. TONY
3. JULIET
4. JULIAN
5. GABBY
6. OTHERS (SPECIFY) _____

The interview schedule

The interview schedule is also a set of questions, but the questions are meant to be asked by an interviewer. The advantages of the interview schedule are as follows (Babbie, 1973):

1. Personal interviews usually yield much better information on the sample of the population compared to questionnaires.
2. The interview is more flexible. If the respondent misunderstands a question, the interviewer can explain it. He/she can also paraphrase the answer of the respondent.

3. The interviewer not only listens to what the respondent is saying but also observes how she/he says it. If he/she wishes to, the interviewer can follow-up a question, thereby obtaining more in-depth information in context.
4. The interview is more appropriate in revealing information about complex, emotionally laden topics through probe questions.

Practical approach to preparing questions

In preparing your questionnaire or interview schedule, you will need to follow a systematic approach. In many cases, and without planning, you tend to list down any question that comes to mind in the hope that you will be able to make use of them. This is a long and tedious process. There is one method which will free you of a number of problems.

Through experience, I have developed a practical approach to constructing questionnaires. For lack of any appropriate term, I call this approach the “matrix system.” This is how it works.

1. List down your research objectives.
2. For each objective, list the corresponding hypotheses you intend to test toward achieving the objective.
3. For each hypothesis, list down possible questions you will need to ask in order that you can test the hypothesis. Usually, you will need two questions to test a hypothesis.

The chances are that for each objective, you may need to have at least one hypothesis; and for each hypothesis, you will need at least two questions. Therefore, this is how your matrix will look like (Figure 12).

OBJECTIVE	HYPOTHESIS	QUESTION
Objective # 1	Hypothesis # 1	Question # 1 Question # 2
	Hypothesis # 2	Question # 3 Question # 4
Objective # 2	Hypothesis # 3	Question # 5 Question # 6
	Hypothesis # 4	Question # 7 Question # 8

Figure 12. Sample objective-hypothesis matrix

This means that for you to be able to achieve your two objectives, you may formulate and test four hypotheses. So that you can test these hypotheses, you need at least two questions for each. Ultimately, you need to ask eight questions. These are the questions you will include in your questionnaire or interview schedule.

There are four advantages of this matrix system.

1. It is a time-saving device. Without it, you may spend more than the necessary amount of time trying to construct your questionnaire.
2. It helps you understand more clearly what you are trying to do. Putting your research objectives, hypotheses, and questions side-by-side will show you the simplicity or complexity of your research project.

3. The matrix enables you to pinpoint at once any vague and unnecessary question, so you can modify or change it without having to look over the entire questionnaire.
4. It helps you organize your questionnaire or interview schedule.

A word about asking questions

How you ask questions has significant implications on the kind of responses you will get. Experience has taught us that certain ways of asking questions can be demeaning to respondents.

For example, you put this question to a farmer: “what is your problem?” This can have negative implications like, it lowers the self-esteem of the farmer because the question implies that he has a problem. Even if it were true that the farmer, indeed, had problems that he perhaps had not realized, he will not feel comfortable with a categorical question implying that he has a problem. Hence he will give you a vague response like “tell me what you can give and I’ll tell you what the problem is.”

On the other hand, if you ask: “where, in the state of your present knowledge, can we introduce additional knowledge that you can make use of?” This has positive implications. It raises the self-esteem of the farmer because it implies that he is knowledgeable and that he can still add to his present level of knowledge. With this kind of question, the farmer will likely provide a more meaningful response.

As has been implied in the previous pages, researchers deal with two types of questions, namely: the close-ended question and the open-ended question. You state a close-ended question in such a way that the answer is definite based on pre-determined choices or perhaps the question

may be answered with either a “yes” or a “no.” Open-ended question, on the other hand, asks the respondent to frame his/her response the way he/she wishes to and not limited to pre-determined choices.

It should be pointed out that responses to close-ended questions are easier to analyze statistically. Responses to open-ended questions normally require you to establish first how you would categorize said responses before you can subject them to rigorous analysis.

Procedure in Collecting the Data

In a thesis proposal, it is very important that you describe exactly how you are going to collect your data. This section of your chapter on “Methodology” should discuss in detail the steps you will follow in collecting your data. In general, you may need to go through the following basic steps:

1. *Administering the research instrument.* If you are using a questionnaire, describe how you are going to proceed. Will you mail the questionnaire? Are you going to include a return envelope that the respondent can use in returning the completed questionnaire? What will you do if the return rate is low? How are you going to ensure high return rate?

A few guidelines will help to ensure high return rate for mailed questionnaires. First, try to get sponsorship. Respondents usually are more likely to respond if the project has been endorsed by persons, organizations, or institutions of prestige. However, do not claim sponsorship unless it is expressly given. Second, be sure to include a courteous, carefully constructed cover letter explaining the purpose of the study. The cover letter should assure the respondent of confidentiality. If you omit such courtesy, you will practically guarantee

that your questionnaire will go directly to the waste basket. Third, adopt a vigorous follow-up procedure. Respondents are always slow at returning completed questionnaires. Reminders and personal letters are effective with those who have forgotten about the questionnaire. In extreme cases, a phone call or a personal visit may result in a higher return rate.

There are no hard and fast rules in determining adequate or satisfactory rate of return of completed questionnaires. However, in general, the smaller the percentage of return, the smaller the degree of confidence one may place in the adequacy of data collected.

2. *Recording observations.* Additional data may be collected through systematic recording of observations. There are pieces of information that the questionnaire or interview schedule may not be able to obtain, but which may be very useful in cross-checking the information obtained from the questionnaire. It could also aid in a more accurate and interesting interpretation of data. For example, a good description of the environment and behavior of the respondent will improve your understanding of your data.
3. *Use of records and documents.* Records and documents are very important sources of additional information. As mentioned earlier, the rule in questionnaire construction is, avoid asking questions whose answers can be obtained from other sources such as records and documents.

The use of these means of collecting data in combination with one another is called triangulation. The significance of triangulation lies in the fact that you can cross-check information obtained from all three sources.



PART II

Writing Your Thesis
Manuscript



Chapter 6

The Thesis Manuscript: an Overview

Your thesis manuscript refers to the write-up of your entire research report. It is the final document that contains everything about your thesis project, including its approval by your Advisory Committee, written in the past tense. Recall that when you wrote your thesis proposal, you wrote it in the future tense. However, you write your thesis manuscript in the past tense since the research is supposed to have been completed. In the thesis manuscript, you are essentially reporting what you have done as well as your findings and analysis of those findings.

This book does not recommend a specific format for the thesis manuscript, except to say that you must follow the manuscript format adopted by your university.

Review Your Thesis Proposal

As a thesis student, you may not have realized it but when you got your thesis proposal approved by your institution (Academic Department, College or School, or University), your work was practically 50 percent completed. All that

has been left for you to do was collect your data, analyze them, and write-up your report. The proposal, therefore, is one of the most important aspects of your thesis experience.

Do a final check of your proposal and make sure that all your tenses are transformed into past tense as this would become part of your thesis manuscript. Check as well whether or not you still need to include additional information, perhaps in the Review of Related Literature.

Conceptual Overview of the Remaining Chapters of Your Thesis

Normally, given the standard format of a thesis, what is left for you to write are two chapters: Results and Discussion; and Summary, Conclusion, and Recommendations.

The chapter in which you present your findings may be called “Results and Discussion” for experimental studies or “Findings and Discussion” for non-experimental studies. Sometimes there are those who would present their results or findings separately from their discussion of those results and findings. It is preferred however, to provide the appropriate discussion of the data or results or findings immediately after you present them. In the same vein, when you make mention of a statistical table or perhaps a figure in your discussion, make sure to present the table or figure right after you have mentioned it. As much as possible, do so in the same page so that there is proximity of discussion and referent object (Table or Figure).

The chapter titled “Summary, Conclusion, and Recommendation” is exactly that. We turn back to the points regarding the framework of the thesis. The summary of your results must, again, reflect your research objectives and hypotheses. Said summary must be reflected in your

conclusions, as well as in your recommendations. It would be a good idea to number those entries. That is to say, your first objective must be reflected in your first hypothesis statement. This, in turn, should be reflected perhaps in your first statement in your summary of findings, which would first be reflected in your set of conclusions. Finally, this would also be reflected in your first recommendation. This flow chart is indicated in Figure 13.

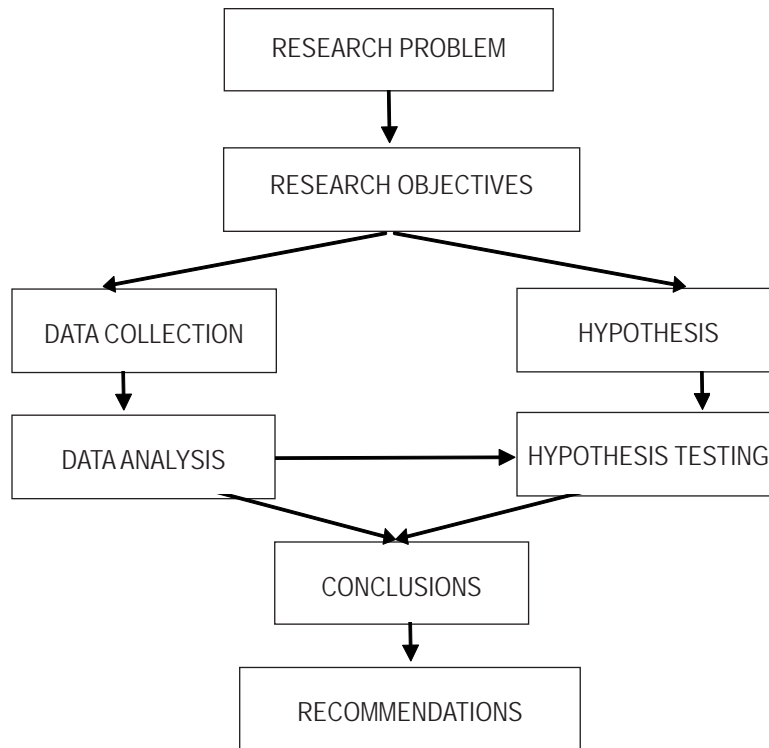

Figure 13. Flow chart in translating research problem to conclusions and recommendations

A Word on Interpretation of Data and Information

Perhaps one of the most important things that you must demonstrate in the chapter titled “Results and Discussion” of your thesis is your ability to appropriately interpret your data and the additional qualitative information that you may have collected. Interpretation, Babbie (2007) explains, is “similar to explanation.” Creswell (2002) puts it this way: “interpretation means that the researcher steps back and forms some larger meaning about the phenomenon based on personal views and/or comparisons with past studies” (p. 277).

In other words, interpretation is really a process whereby you try to establish what lessons you may have learned from the collection and analysis of your data in relation to your research experience. When you interpret your data, you are trying to reflect on the probable meaning of your data in relation to your understanding of what appears in the scientific literature about your research problem. This means that you are drawing inferences from your data and information to form some conclusions about what you may have learned from the research experience.

Establishing the Ambiance of Interpretation

Before you begin writing the chapter on results and discussions, you need to go back to your research problem and study again how you described the said research problem. Relate again your research problem with the objectives of your study as well as with the hypotheses you set out to test, if you had any. Then recall the synthesis

of your review of the related literature, trying to highlight how potentially similar data may have been interpreted by previous researchers. All these, you need to relate to your own experience and try to draw observations that could help you explain more accurately and meaningfully what your data appear to provide mean.

Frequently, thesis students tend to make sweeping statements that sound conclusive even if the data from the thesis could not provide enough evidence in support of said statements. This is an error that you must try to avoid. When you phrase your discussion, use terms that may sound tentative because that is what your results are – tentative rather than absolute. Let us consider a hypothetical research write-up on a make-believe study of water pollution in a particular creek that we are calling “Molawin Creek.” Instead of saying, “the results of this study definitely indicate that the Molawin Creek is completely polluted,” you might rephrase this to read, “the results of this study indicate the presence of above-normal levels of arsenic in the waters of the Molawin Creek.”

Statements such as the one suggested in the previous paragraph provides some amount of leeway for readers of your thesis to make their own conclusions based on what they make of your findings. Given the amount of information that they could get from your data, they may arrive at a conclusion different from yours. This is important, especially when the reader may have gained much more experiences compared to yours in doing similar studies.

One of the most important considerations when you write your thesis manuscript is to make guarded conclusions, even if you may feel absolutely certain that you have gathered enough evidence to support your definite claims. Your thesis is only one study, and in spite of what you

may believe, it has its own limitations. One study simply cannot be enough basis for making generalized statements that could apply to all situations. At best, it can contribute towards the establishment of more data and information that, when put together, would lead to applicable and acceptable generalizations at a later date.

Chapter 7

Analyzing Your Data

In this section of your write-up, we discuss how you have chosen to present and analyze your data. There are two types of data analysis techniques (quantitative and qualitative analysis), which you can employ either individually or in combination with each other. Obviously, a combination of these two techniques would be much more meaningful.

Before discussing how to analyze data, let us look at the concept of measurement first.

Measurement

Measurement implies that you have expressed your study's variables in quantitative terms. The level of measurement to be employed determines what statistical methods you can appropriately use in the analysis of your data. When you deal with quantified information, you are going to do quantitative analysis. However, when you are going to do qualitative analysis, you must also have a mastery of interpreting quantified information.

Various measurement scales would offer you various opportunities and options in interpreting your data because different measurement scales offer varying degrees of exactness or preciseness in describing given characteristics of a phenomenon. Measurement scales offer you a range from low to high in the amount of information they can provide, so we normally talk in terms of levels of measurement. It is important that we understand the levels of measurement for reasons Williams (1968) provided, thus:

1. selection of measurement scales depends on the type of information that you want to record.
2. the scale that you select may place restrictions on what models of statistical reasoning you may be able to apply.

The four types of measurement scales (McBurney and White, 2004; Pittenger, 2003; Williams, 1968) are nominal, ordinal, interval, and ratio scales.

Nominal scale

Nominal scale is defined as the “assignment of numbers or symbols for the purpose of designating sub-class, which represents unique characteristics” (McBurney & White, 2004; Pittenger, 2003; Williams, 1968).

The nominal scale is used to identify classes. For example, the numbers worn by athletes identify one player from another. That is to say, the number “7” refers to a particular player by the name of Robert Jaworski who was the playing coach of the Ginebra basketball team in the Philippine Basketball Association, while the number “23” may refer to another player.

The serial number on a television set does not tell us anything about the quality of the television set, but this number distinguishes it from other styles of the same model.

The nominal scale is also sometimes called the classification scale. However, it is the weakest level of measurement. It provides the least amount of information compared to other measurement scales.

When we classify our observations into mutually exclusive categories such as in dividing a class into sub-classes, we use nominal scale. For example, "sex" is a class, and the subclasses of "sex" are "male" and "female." The subclasses may be arbitrarily assigned such that male = 1 and female = 2, to facilitate easier analysis.

Ordinal scale

Ordinal scale is the assignment of numbers or symbols for the purpose of identifying relations of some characteristics, the order having unspecified intervals (McBurney & White, 2004; Pittenger, 2003; Williams, 1968). This scale is more sophisticated compared to the nominal scale. Here, larger scores reflect more of the quantity or quality, but units along the scale are unequal in sizes.

An example is the order of winning scores in horse racing. There is a first placer, a second placer, and a third placer. However, the distance between the first and the second is not necessarily equal to the distance between the second and the third. The important point here is that among the subclasses, there is an interrelationship or rank ordering. In other words, a subclass may be compared to another subclass in terms of "greater than" or "lesser than" relationship.

The "greater than" nature of the classification may be dependent upon the nature of the characteristics under study. For instance, it may indicate such relation as "more preferred," "more emotional," "more aggressive," "more ethical," and the like.

The ordinal scale, however, does not represent the magnitude of difference between ordered categories.

Interval and ratio scales

McBurney and White (2004), Pittenger (2003), and Williams (1968) defined interval and ratio scales as follows: interval scale is the “assignment of numbers for the purpose of identifying ordered relations of some characteristics, the order having arbitrarily assigned in equal intervals but with an arbitrary zero point.” Ratio scale is the “assignment of numbers for the purpose of identifying ordered relations of some characteristics, the order having been arbitrarily assigned in equal intervals but with an absolute zero point.”

In summary, these are what scales can do:

Scale	What It Can Do
Nominal	enables you to use statistical tools that can help you analyze frequency data for each classification;
Ordinal	enables you to use statistics to describe the way the cases are ordered with respect to a variable;
Interval	permits you to compare quantitative differences among cases on a scale; and
Ratio	permits you to compare absolute distances between cases.

Quantitative Analysis

For all intents and purposes, when you say quantitative analysis, you are referring to the use of statistical tools. In social science research, two types of statistical analyses are normally employed: descriptive statistics and inferential statistics.

More commonly used by social science researchers, descriptive statistics summarizes certain aspects of the data. There are two groups of descriptive statistical tools: measures of central tendency, and measures of variability or dispersion. The reason why these are called descriptive statistics is because they simply describe the data in quantitative form.

Measures of central tendency. The concept of central tendency really means that the data tend to cluster around the center of the distribution. That is to say, in a bell-shaped frequency distribution, most of the cases tend to group around the center. The three measures of central tendency are arithmetic mean, median, and mode.

Measures of variability. Also known as measures of dispersion, the measures of variability mean that you are measuring how far from the center of the distribution the scores are being dispersed.. In other words, dispersion is a measure of the tendency of scores to move away from the center of the distribution. The measures of dispersion are range, semi-interquartile range, mean deviation, and standard deviation.

Inferential statistics, on the other hand, refers to statistical procedures that enable you to draw inferences. When you employ inferential statistics, you can make statements about a population based on your observation of a sample from the population.

This book does not offer lessons in statistics. If you wish to read up on the topic, get hold of a statistics textbook. Perhaps the most sensible thing that this book offers is a suggestion that you consult a statistician who will help you determine what statistical tool would be most appropriate to your thesis given the nature of data you will have to deal with.

Qualitative Analysis

Qualitative data analysis deals with the analysis of information, such as texts, rather than quantified data. This involves the description of the information and developing themes. When you interpret information or themes, you situate your findings within a larger, more abstract realm of meanings. You are not completely dependent on numerical facts but more on your understanding of the meanings of information and how they relate to one another under specific situations or conditions.

This form of analysis is also called non-quantitative analysis. In the process of interpreting data, you do not put emphasis on quantification but rather on the quality of the information. Raw data can be used as basis for interpreting information. This fulfills two functions as follows:

1. *Illustrating the meaning of categories.* The use of illustration in defining categories is useful because it adds to your understanding of the material. It is not uncommon, for instance, that in many research reports respondents are quoted verbatim. Let us look into a hypothetical case, an analysis of reasons that prompted people to move from a housing project. A group of researchers introduced a distinction between those who had to leave and those who wanted to leave their old residences. In this hypothetical case, there seems to

be a distinctive dividing line between the two groups. However, illustration of both categories indicated that the dividing line was sharp in some cases and vague in others. One tenant explained, "the house was sold without my knowledge," therefore, he had to move out. Another one commented, "I don't like the people in the neighborhood." Well, it appeared he wanted to move out.

2. *Stimulating new insights.* Whatever the design of the study, and no matter how refined its statistical procedures, more important insights may be arrived at by inspecting the raw data. The inspection of non-quantitative data may be particularly helpful if it is done periodically throughout a study rather than postponed to the end of the statistical analysis. Frequently, a single incident noted by a perceptive observer may contain the clue to understanding of an event. If you become aware of this implication at the moment when you can still add to your material or exploit further your data, you may considerably enrich the quality of your data interpretations and conclusions.

The use of schematic diagrams or a map of the structural relationships of variables can be very interesting because this enables the reader to look at the variables from another point of view. For example, in the study of the management problems of a rural educational radio broadcasting station conducted by Flor (1982), various elements were found to influence the problem of management. These could not be quantified in a manner that they could be easily understood. Therefore, Flor constructed the problem structure map shown in Figure 14 (appropriate discussion of this methodology is found in Appendix D).

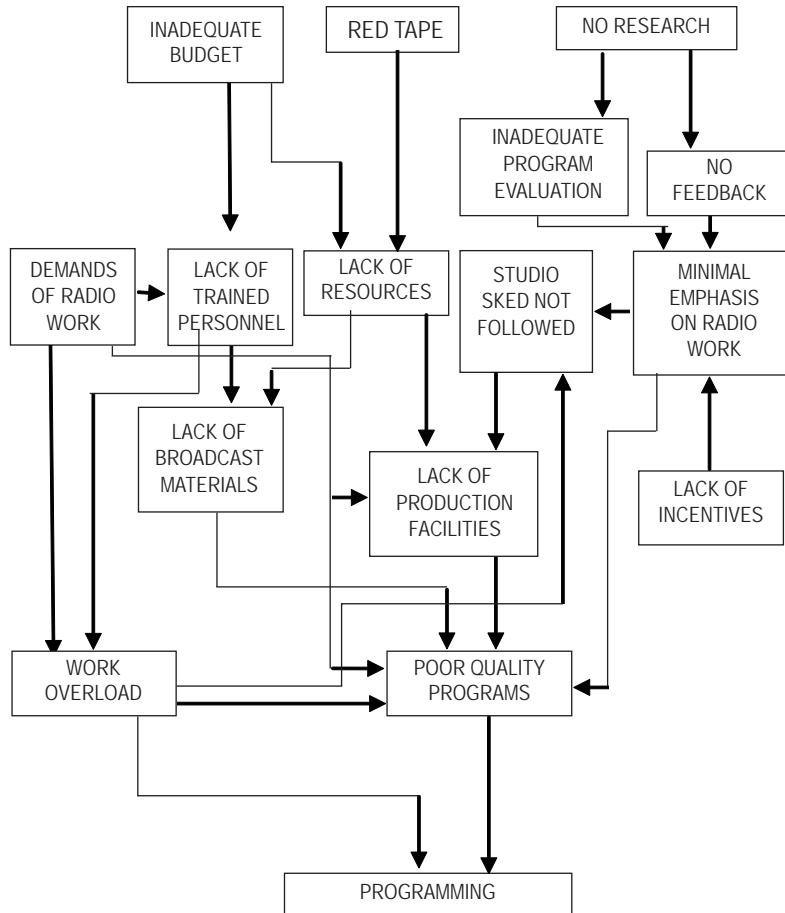

Figure 14. Problematique map of the programming critical function of a rural educational broadcasting station*

*Reproduced from Alexander G. Flor, Problem structure and cost analyses of a rural educational broadcasting station. Unpublished MS thesis, University of the Philippines Los Baños, 1982, p. 86.

In communication research, there is a very high probability of results being statistically significant, but of little importance in real world situations. Significance from the point of view of statistics and from the point of view of reality are two different things. Hence, the need to do qualitative analysis of data as well.

Summarizing Your Findings

Practically all these require that you prepare a summary of your findings. How do you do this? Let us recall the research framework discussed earlier in this book, particularly Figure 6. The summary must reflect your research objectives and hypotheses. The presumption is that you need not include in your summary of findings those that do not reflect your research objectives. How do you present the summary of your findings? One way is to construct a narrative about the results you have found according to your objectives. This could be tedious and even confusing. The more preferred procedure is to number and present your summary sequentially according to how you listed your objectives and hypotheses. If for each objective you have at least one hypothesis, then you should have a summary statement for each hypotheses that you tested.

Sometimes it is tempting to include in the summary of findings, say, demographic information on your respondents. However, if you do not have a specific objective statement regarding the nature of demographic information about your respondents, then it would not be necessary to include statements about demographics in your summary section.

Formulating Your Conclusions

Stating conclusions based on findings appears easy on first look, but in reality how you state your conclusions may spell whether or not they are going to be useful or simply serve to confuse your readers. Over the years of serving as thesis adviser to numerous students, I have observed that many have the tendency to include in their conclusion statements, especially in draft manuscripts, good-sounding conclusions that do not actually have basis. This is a very serious error.

How do you make sure that you are making relevant conclusion statements? There are two ways of approaching this task. One, your conclusion may be based on your thesis objectives. Two, your conclusions may be the result of testing the hypotheses you set out to test, which are also on your thesis objectives.

It is best to present your conclusions on a one-on-one correspondence with your objectives and hypotheses. You must remember that any conclusion that you have to make must be based on the results or findings of your study. Besides, any conclusion you have to make must be a reflection of your research objectives and hypotheses tested.

A Word About Making Recommendations for Further Study

Making recommendations on the basis of your thesis results seems always easy. In fact, not a few have told me that this was perhaps one of the easiest things to do. However, a serious look at the manner in which you can formulate your recommendations would reveal otherwise.

Having done your thesis, you will be writing about what you can recommend that other researchers might consider doing based on your thesis results. Frequently, you can come up with either of two types of recommendations. First, you may recommend a set of practical actions that could right away be implemented. Usually, these recommendations are suggestions on how to solve the problems initially identified by your study that needed to be resolved. Second, you might prefer to highlight the need to undertake further studies because your results may not be conclusive enough. This is the more significant type of recommendation, which normally becomes part of your thesis' contribution to the build-up of the body of literature and perhaps knowledge in your discipline.

How does this work out? Let us have a closer look at the process of arriving at the recommendation for further study. Many recommendations for further study that I have seen would simply state, thus: "it is recommended that further studies of this nature be conducted to generate more conclusive results." This statement of recommendation really does not mean much. If anything, it makes matters confusing. Here are things that you might consider doing:

1. On the basis of your review of the scientific literature, formulate a composite framework or a diagram of the interrelationship of variables (some would refer to this as model) that you can field test. You will base your questions or procedure for gathering data on this framework or model showing how the variables involved are interrelated. (Remember that when you formulated the hypotheses of your study, these variable relationships were your bases.) When you apply the framework and start asking questions pertaining to the model's applicability on the ground, you are essentially field testing said framework or model.

2. In the process of analyzing the data you had collected, you will most likely observe that there might be new concepts or variables that you have uncovered but which may not have been originally part of the composite model you have field tested. As a result, therefore, you would incorporate your newly-identified variables into the composite framework or model you have constructed based on your review of the literature. The resultant framework or model, in which you already have incorporated your suggestions, would become the revised framework or model that still needs some further testing.
3. This revised framework is the basis of your recommendation for further research. However, your recommendation is not simply a motherhood statement on the need to conduct further studies. The revised framework or model shall be your basis in formulating research hypotheses that could be tested by future researchers. These hypotheses would constitute part of the contribution of your study to the body of knowledge. In other words, you are recommending that future researchers test the research hypotheses that you have formulated based on the results of your study.

The best recommendation that your thesis can make is to test the research hypotheses that you have formulated on the basis of your findings. This highlights two things.

First, it makes the statement that the results of your thesis are inconclusive and would need additional evidence to become basis for substantial and useful generalization. Experience tells you that many thesis students make it appear as if their respective theses have resolved all the problems that they may have thought of as they started out to do their theses. I have always advised my students, "do not try to solve the problems of the world with just one little thesis because that is impossible."

Second, recommending the testing of a well-written research hypothesis is an indication that you have understood well your research and that you know exactly what is still needed to make it useful. Besides, this is the most concrete thing that you can do with your findings. Remember that this is the most important contribution of your thesis to the existing body of literature and knowledge about the topic of your thesis.



Chapter 8

Visualizing Your Results

That you have written your thesis well does not mean it will be read and if read, that it will be understood well. Indeed, you need to find ways of making it easier for your reader to comprehend your research report. This is usually done through the appropriate use of visuals, such as graphs, charts, illustrations or drawings, and photographs. This is the subject matter of this short chapter.

Use of Statistical Tables

Quantitative data are usually presented in statistical tables. This makes it easier to understand such information. There are two types of tables: informal and formal tables.

The informal table is one that has no table number and title, usually small, and always part of the textual presentation. This type of table has no lines (rules).

The formal table, on the other hand, has a table number, a title, and all the parts of a complete table. According to the CBE (Council of Biology Editors) Style Manual, most tables have the following parts:

1. Table number and title.
2. Box heading. This identifies the entries in the vertical columns.
3. Stub/Side heading. This identifies the entries in the horizontal rows.
4. Field. This part of the table contains the data being presented.
5. Footnotes. These describe specific aspects of any part of the table; also contains the source of the table or information if these are sourced from elsewhere.

The lines on a table are called rules. Normally, there are three horizontal rules: one above and another below the box heading, and a third below the field. There can be more rules, depending on necessity. Another type of rule is called the straddle rule, which separates the box heading and the sub-heading

It used to be that vertical rules were required across the field. However, these are very expensive to construct and print in journals. Hence, style guides have discouraged their use as long as the data are properly arranged according to headings.

The following shows the different parts of a table (Table 1).

ECOSYSTEM	FUNCTION				
	A	B	C	D	E
Irrigated	3	18	63	15	11
Rainfed Lowland	4	18	53	26	4
Upland	4	15	53	24	6
Deepwater	5	9	68	12	3
Tidal Wetlands	5	22	46	22	2
Cross Ecosystem	5	21	46	28	10
MEAN	4	17	52	21	6

- FOOTNOTE
- A = policy making
 - B = program planning/administration
 - C = research
 - D = teaching/training
 - E = others

Table 1. Amount of time devoted to functions in ecosystem (%)

SOURCE: Librero, Felix. (1992). *Scientific information and the rice scientist*. College, Laguna: IRRI.

A note on the use of tables

You want people to get the feel of your results, that is why you present such results in statistical tables. However, when used too much, tables become boring. Most likely also, when you use too many tables, it inadvertently shows off your ignorance of your research. However, if you use tables properly, this will show that you are a professional who not only knows when to present important information about your thesis but also how to present your results in the most effective and efficient way.

Interaction tables are preferable because they tend to provide more meaningful information than too many simple tables that provide limited information like what tables of single variables do.

If you are dealing with descriptive materials, perhaps you would be better-off using graphs or algorithmic models or flowcharts.

Techniques of Visualizing Research Information

Heinich, Molenda, and Russell (1982) provide a general classification of presenting information into charts and graphs.

Charts

There are five types of charts you can choose from.

1. *Organizational chart*. This kind of chart shows the hierarchical relationship of personnel and sub-units of an organization. A classical example of this kind of

chart is the military organization, which is normally structured in a formal hierarchical structure as shown in the following:

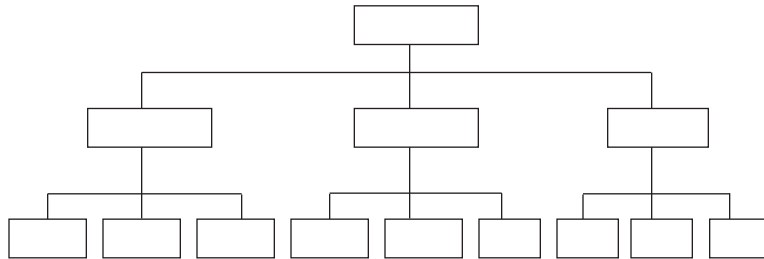

2. *Classification chart.* This is used mainly to categorize objects, events, conditions, or species. In the field of management, one of the more popular models is Maslow's hierarchy of needs, as shown in the following diagram:

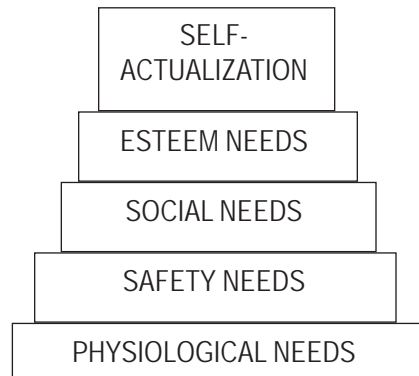

Adopted from: Reitz, H. Joseph. (1977). Behavior in organizations. Homewood, IL: Richard D. Irwin, Inc.

3. *Time line.* This kind of chart illustrates the chronological relationship of events through time, as in the case of historical events depicted according to the approximate time when they occurred. You can use pictures and drawings symbolic of the events arranged along a time

line to show the relative period when the events took place. This technique is helpful in summarizing the time sequence of a series of events.

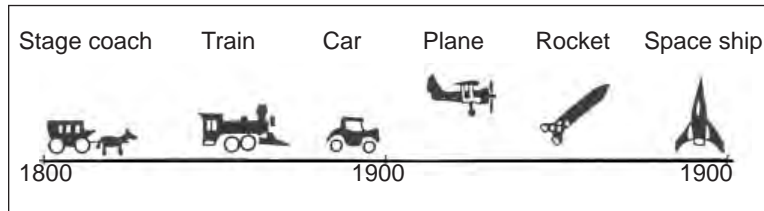

SOURCE: Heinich, Molenda, and Russell, (1982). *Instructional media and the new technologies of instruction*. New York: John Wiley & Sons.

4. *Tabular chart*. This chart contains numerical information or data. This book suggests that you arrange your numerical information in a manner you feel comfortable with, but with a pattern. For example, you may arrange your entries in the stub or side heading of your table in a particular way like in alphabetical order, or you may arrange your entries according to the values shown in the field of your table, as shown in the following example:

ECOSYSTEM	FUNCTION				
	Research	Teaching/ Training	Pgm Planning/ Admin.	Policy Making	Others
<i>Deepwater</i>	68	12	9	5	3
<i>Irrigated</i>	63	15	18	3	11
<i>Rainfed Lowland</i>	53	26	18	4	4
<i>Upland</i>	53	24	15	4	6
<i>Tidal Wetlands</i>	46	22	22	5	2
<i>Cross Ecosystem</i>	46	28	21	5	10
<i>Mean</i>	52	21	17	4	6

SOURCE: Librero, Felix. (1992). *Scientific information and the rice scientist*. College, Laguna: IRRI.

5. *Flow chart.* This is also known as process chart. It shows a sequence of procedures or “flow” of a process. The flow chart is normally drawn horizontally and shows how different activities merge into a collective whole. You can, however, construct your flow charts either horizontally or vertically, or both, depending on the pattern you want to depict. Here is an example of a horizontal flowchart:

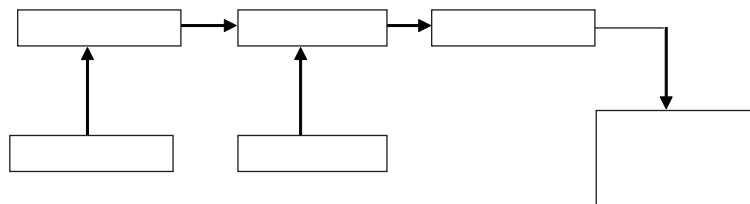

Graphs

1. *Bar graph.* By convention, the bar graph is normally drawn vertically. However, horizontal bar graphs are already common and are as effective. The height of the bar is the same as the approximate quantity being represented. The width of bars should be the same to avoid confusion. A single bar can also be divided to show parts of a whole.

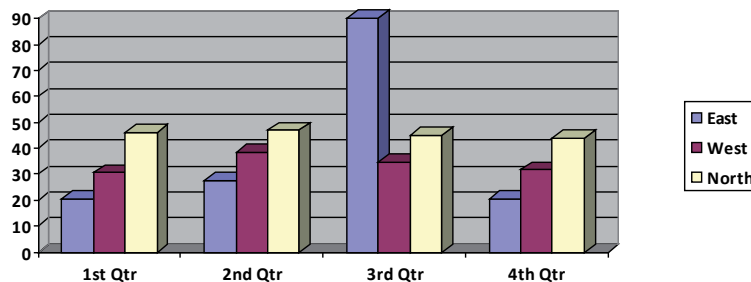

2. *Pictorial graph.* This is an alternative format to bar graph. A series of simple drawings is used to represent a particular value. Pictorial graphs are usually interesting and more appealing. Since pictorial symbols are used to represent a certain value, partial pictorial symbols may represent fractional quantities.

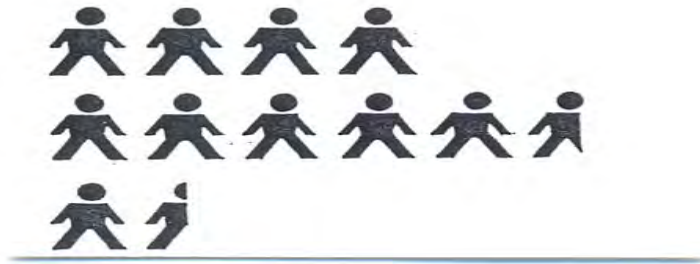

SOURCE: Heinich, Molenda, & Russell, 1982.

3. *Circle (pie) chart.* One typical use of the pie chart is to depict budget allocations. It could also be used to show relative distribution of samples in terms of proportions.

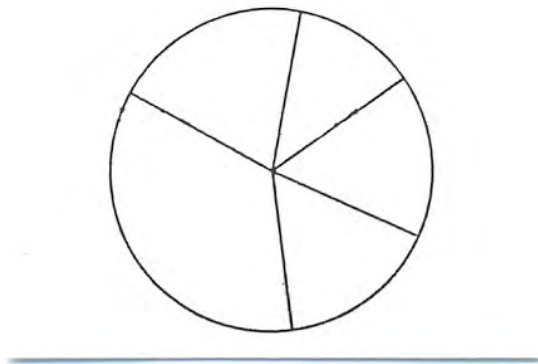

SOURCE: Heinich, Molenda, & Russell, 1982.

4. *Line graph.* In statistics, this is also called a histogram. The line graphs are based on two scales at right angle. Each point has a value on the vertical and horizontal scales. The lines are drawn by interconnecting the points. The line graph is very useful in plotting trends.

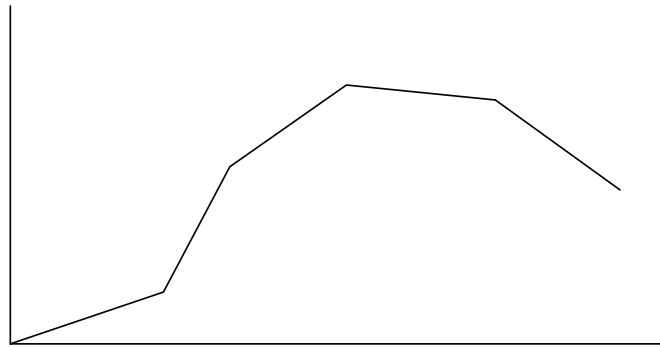

SOURCE: Heinich, Molenda, & Russell, 1982.

Use of Illustrations and Drawings

Sometimes it may not be enough that you use charts and graphs and statistical tables. You may need to use illustrations or sketches to demonstrate in visual symbol the concepts or ideas you have described in your text.

According to Wikipedia, an illustration is an “image presented as a drawing, painting, photograph or other work of art that is oriented to elucidate or dictate sensual information (such as a story, poem or newspaper article) by providing a visual representation graphically.” When you are visualizing information that is technical in nature, Wikipedia says that you are using technical illustration, which it defines as the “use of illustration to visually communicate information of a technical nature.”

An example of an illustration may be a stick drawing of a person doing some specific activity, or even a map of a specific place, such as a tourist map depicting relative locations of places to see in large tourist destinations. Comic strips are also an example of illustration of stories. Drawings, on the other hand, are a subset of illustrations that are more realistic representation of realities. You use drawings if you do not have an actual photograph of a person, event, or place you want to show as a visual depiction of your textual report.

Use of Photographs

A photograph, according to experts, is an image of reality that is created when light strikes a light-sensitive material like film, or an electronic imager such as what are now commonly called memory chips used in digital cameras (<http://en.wikipedia.org>). Pictures have the advantage of being able to represent in visual form reality at a specific point in time. That is, pictures can freeze events so that such events are made permanent. This capability of photographs make them ideal means of showing how certain events or phenomena appear to an observer at a particular time.

In a project undertaken by Watson and Lom (2008) to train undergraduate biology students to use images in communicating scientific information, they arrived at the following conclusion:

. . . learning to communicate using images instead of or in addition to words is a powerful skill that is an essential component of a developmental biologist's toolkit and is also transferrable to many other areas of communication and science. We believe the evaluative and creative levels of reasoning that students gain by developing skills in visual communication will help them communicate and evaluate claims more effectively in both academic and non-academic aspects of their lives (p. 34).

It has been said that a picture is worth a thousand words, and this may well be true in relation to the use of pictures to visualize scientific phenomena that are difficult to explain in words. Furthermore, a picture is most effective in showing the effects of interventions such as in before-after picture comparisons.

Indeed, sometimes there are situations that you can hardly express in numbers but can appreciate better in visual form.



Photographs by the author (2011)

A Word About Errors in Observation

According to Ackoff and Emery (1972), there are four possible sources of error in observation. These are (a) the observer himself, (b) the observed, (c) the instruments used in making observations, and (d) the environment in which the observations are made. Additionally, under these conditions, there are three possible types of error, which are (a) observing inaccurately, (b) seeing something that is not there, and (c) not seeing something that is there. Given these, therefore, you can say that some people are better observers than others.

Ackoff and Emery (1972), cited Kirk and Talbot (1966) as having named the following types of observational errors:

1. *Systematic distortion (SD)*. The information is not lost, but it is changed. This distortion can be eliminated or corrected by application of rules that specify appropriate transformation procedures. SD is like the instrument-produced distortion of figures in rear-view mirrors that are cylindrically convex, which can show more than a flat mirror can. The effect is that you can see images that are not normal, like they may be very thin and tall, and the like. Another example is a bathroom scale that is improperly set. It will give you the wrong weight.
2. *Fog*. In this kind of distortion, you fail to see what is there. Under this condition, the information is lost. It is “fogged” over. A good example here is a person who is color-blind. He fails to observe color. A second example is a sound recording instrument that fails to record very low frequencies. In communication, ambiguity is considered a fog.
3. *Mirage distortion (MD)*. Here, you see something that is not there. This is the opposite of “fog.” Instead of withholding information from you, MD gives you more than what you want.

The four sources of observation error which give three types of errors may be shown in Figure 15.

Source of Error	Type of Error		
	SD	Fog	MD
Observer Observed Instruments Environment			

*Figure 15. Sources and types of observation errors**

*Adopted from Ackoff and Emery, 1972, p. 266.



Chapter 9

Practices in Citing Sources

It is very tempting to go all the way and discuss in detail each of the common style guides that may be available or being practiced. However, this book is not a style guide. This book suggests, therefore, that you review any of the current style guides that you might want to follow. If you do not have access to the full-blown print versions of the different style guides (which may be available in huge, expensive thousand pages), you may refer to the abridged versions that may be available online. Your best option would be to follow the style guide that has been adopted by your institution, or follow what your adviser suggests you follow.

Still, let us briefly discuss here the concepts of citation and the bibliography.

Citation

In the academic community, the term citation is a very important concept. It is the attribution to a previous work an idea being reported or mentioned in a current work such as your thesis. Citation is intellectual honesty because you are telling your readers that what you are reporting or writing about is not your original idea but that of another individual, who you are essentially referring to as your source. When you cite a source, it means you are giving credit to where it is due, and not owning something essentially not yours.

Generally, there are two ways of citing your sources.

In-text citation. This refers to the practice of giving the name of the author from whose work you have taken an idea and used it in your work. When you cite your source within the text of your report or write-up, you can do it in either of the following:

Example 1: Nominal scale is defined as the “assignment of numbers or symbols for the purpose of designating sub-class which represents unique characteristics” (Williams, 1968).

Example 2: Williams (1968) defined nominal scale as the “assignment of numbers or symbols for the purpose of designating sub-class which represents unique characteristics.”

Footnoting. Turabian (1955) has sufficiently explained the functions of footnotes which are a) to cite authority for statements made in the text, b) to make incidental comments that cannot be appropriate part of the text, c) to provide cross-references, and d) to acknowledge a source. However, use footnotes sparingly. Do not use them simply for scholarly appearance.

Traditionally, you write the footnote citation at the bottom of the page where you made the citation, separated from the text by a horizontal line from the left margin to the center of the page. Footnotes are single-spaced, with double spaces between citations. The first line of the footnote should be indented (normally five spaces), and any succeeding line should be flushed left.

Example:

¹Ma. Celeste H. Cadiz. Educational Communication for Development (College, Laguna: UPLBCA Publications, 1991), p. 38

Bibliographic Entries

The term general bibliography refers to a listing of materials that have helped you in developing your thesis. Not all of these materials may have been mentioned in the body of your thesis manuscript though. On the other hand, the specific bibliography (also known as “List of References” or “References Cited”) is a list of materials that were cited or mentioned in your manuscript.

Bibliographical entries differ in the different academic disciplines. For example, in general, the social sciences have adopted the American Psychological Association (APA) Style Guide; the natural sciences use the Council of Biology Editors (CBE) Style Guide; and the humanities and the arts use the MLA (Modern Language Association) Style Guide. Generally, a combination of these styles have been adopted. For example, the style guide that Turabian originally wrote in 1955 (*A Manual for Writers of Term Papers, Theses and Dissertations*) has been refined to include elements of the other style guides to make it easier for graduate students to adopt. It should be pointed out that the Turabian Style Guide highlights the use of footnotes.

As a general piece of advice, follow either the conventions in the three different style guides, depending on your disciplinary area. Those in the social sciences follow the APA Style Guide. Those in the natural and mathematical sciences, follow the CBE Style Guide. And those in the humanities and the arts, follow the MLA Style Guide. However, graduate students may still want to go by the Turabian Style Manual (refer to the latest edition). The safest, however, is for you to follow the style that has been adopted by your institution or university.

Here are sample bibliographic entries for book:

The APA Style Guide:

Librero, Felix R. (2008). *Distance education in the Philippines*. Los Baños, Laguna: U.P. Open University.

The MLA Style Guide:

Librero, Felix R. *Distance education in the Philippines*. Los Baños: UPOU, 2008.

The CBE Style Guide:

Librero F. *Distance education in the Philippines*. Los Baños: UPOU; 2008. 246p.

The Turabian and Chicago Style Guide:

Librero, Felix Robillos. *Distance education in the Philippines*. Los Baños: UPOU, 2008.

The Harvard Style:

Librero, FR. 2008, *Distance education in the Philippines*, UPOU, Los Baños.

The Issue of Plagiarism

Plagiarism may not be a criminal offense, but it is a very serious moral and ethical offense in the academe. Unfortunately, even in the academe, particularly among students, plagiarism is not well understood. Many are not aware of it, and many more do not know what it is.

In January 2011, I was invited by the UPLB School of Environmental Science and Management (SESAM) to talk about plagiarism in its monthly forum, Talakayan Series on Environment and Development. Let me quote liberally from that presentation. In that presentation, plagiarism was defined, thus:

What is plagiarism? Wikipedia, quoting the Random House Compact Unabridged Dictionary published in 1995, and the Oxford English Dictionary, offered the following detailed definition of plagiarism: “the wrongful appropriation, close imitation, or purloining and publication, of another author’s language, thoughts, ideas, or expressions, and the representation of them as one’s own original work.”

Others have defined the word in simpler, more direct terms. For example, Stephen Moss (2005), writing for The Guardian, defined plagiarism as “the attempt to pass off the ideas, research, theories or words of others as one’s own.” He said, plagiarism is a serious academic offense. The website of the Southern Connecticut State University (<http://www.southernct.edu>) used in its entry on plagiarism the title “Plagiarism is Cheating.” In another website (<http://www.plagiarism.org>) plagiarism was referred to as “fraud,” which means “outright deception, and sometimes almost ‘accidental’ misrepresentation,” or from the point of view of financial investments, “failure to disclose or to tell the whole truth” (<http://www.fraudlaw.org>). At the University of California (Davis), plagiarism is defined as “using another’s work without giving credit,” and the student is tersely reminded that “scholarship

entails researching, understanding, and building upon the work of others, but also requires that proper credit be given for any 'borrowed' material" (<http://sja.ucdavis.edu>).

As reported by Wikipedia, it was in the 18th century, in Europe, when new morals and ideals were institutionalized and applied in academia and journalism. In these institutions today, "plagiarism is now considered academic dishonesty and breach of journalistic ethics, subject to sanctions like expulsion and other severe damages" (<http://en-wikipedia.org>). Wikipedia also pointed out that this was not so in the arts. Referring to the 18th century as point of reckoning, Wikipedia explained that "in the previous centuries authors and artists were encouraged to 'copy the masters as closely as possible' and avoid 'unnecessary invention.'" Indeed, as Palanca Hall of Fame Awardee Butch Dalisay (2010) observed, "... artistic creation often begins with unabashed imitation. Back when people had fuzzier notions or cared less about copyrights and what we today would call 'intellectual property,' writers often filched plots and stories from one another, or from those who came before them." In fact, a quote attributed to poet TS Eliot says, "immature poets imitate; mature poets steal" (Moss, 2005). Of course, that quote was referring to a period prior to the 18th century, not today.

I have frequently heard comments in the past that it would be difficult to create original work anymore in today's knowledge environment. Everything that you discuss in your classes, with friends, or colleagues have been based on previous works done by others ahead of you. When you write your term papers, essays, theses, or dissertations, you are actually using the works of others to build your own work. This was how I explained this situation in my presentation at SESAM:

Contrary to what many believe, however, it is still possible to come up with original work today. What would constitute an original work? In the academe, you're given

tremendous doses of data, information, and knowledge distilled or otherwise transferred from previous works of others. By themselves, these pieces of data or information would not mean much beyond definition of terms or phrases. However, you can come out with original ideas or new interpretations out of these data, information or knowledge. This process is called in education knowledge construction. The new knowledge that you're able to determine and define, or otherwise construct, based on what existing knowledge says constitute new knowledge (especially if what you've come up with is something different from the original ideas in your sources), would be your original contribution to the literature or current body of knowledge. Put simply, new and different interpretation of similar facts and information would constitute new information or knowledge. Of course, acceptability of it in the community of experts would be a different matter.

Can we easily detect plagiarism? Yes, we can. On the whole, we should begin doubting the originality of a piece of work, such as a term paper or thesis, when we see any or all of the warning signals given by Baggaley (2010), which I have summarized as follows:

1. *Multiple styles in English.* I refer to this as the “too-good-to-read syndrome.” You can hardly detect anything wrong with the paper from grammar to logic, except perhaps some incoherence among paragraphs that could be considered the hall mark of unretouched product of the “cut-and-paste” technology.
2. *Assignment is too long.* You might be getting papers perhaps having more than 5,000 words instead of just 2,000, as you might expect from the nature of the content. When a student turns in a lengthy paper that appears to be well-organized and written, especially when there is hardly enough time to do a good job of it, begin to wonder whether or not said student really did all the work. Of course, it goes without saying that you must

be familiar with the writing styles of your students. We do have graduate students who are good writers.

3. *Assignment may be off-topic.* This could be the result of today's "cut-and-paste" technology. The submission may, in fact, be dealing with the same topic as assigned but the orientation of the write up may be different from what is expected. That means being out of topic.
4. *Presence of give-away terms* like "this article ...," "as indicated in the previous paragraph" ..., or even having many paragraphs put together to form a single paper and yet the paper is incoherent.
5. *Citing literature that is not related to the course materials.* This is a clear sign that the material was most likely done by another person not familiar with how the topics in the course are treated. There's a good chance that this is a product of the cut-and-paste technology,

We may be able to detect plagiarism quite easily, but resolving it is a bit more difficult because plagiarists always claim innocence as defense mechanism. For instance, Baggaley and Spencer (2010) reported the following mechanism tools of a plagiarist that they call "protestations of innocence":

1. Protestation of indignation, where the plagiarist, when confronted with the evidence that he has plagiarized, would insist, quite angrily, that he has never plagiarized in his entire life;
2. Protestation of exaggeration, where the plagiarist claims that the accusations against him were exaggerated;
3. Protestation of blame, where the plagiarist would argue that his teachers should have told him of his behavior earlier on, implying that he could have changed his behavior;

4. Protestation of confusion, where the plagiarist would claim that since he has done the same thing over and over he may have lost sight of the extent to which he may have committed plagiarism; that he may also claim that this might have been due to the fact that he is from a different culture;
5. Protestation of ignorance, where the plagiarist would try to explain that until now he had never really understood completely the meaning of plagiarism; and
6. Protestation of the academic validity of plagiarism, where the plagiarist, realizing that he would be expelled from the university, would suddenly confess that he had for a long time been compiling quotations and that he has started using them in making his assignments. In revealing this strategy, he might be trying to justify that what he has been doing was an acceptable approach for him to cope with his academic work or assignments.

Here are some very important reminders about plagiarism:

There is a concept that stands out in importance where plagiarism is concerned. This is the concept of “common knowledge.” If something is considered “common knowledge,” you don’t need to cite your source. Common knowledge, however, differs from one type of audience to another. When you deal with non-common knowledge, you’ll have to incorporate your citation in your text. There are three ways of incorporating your citation in your text, namely: quote, paraphrase, or summary, according to the rules on plagiarism at the Jackson State Community College in the US (<http://www.jsc.edu>).

The quote

A quote, according to the Jackson State Community College, is “an exact reproduction of an author’s exact words in your own text.” There is a caveat in using quotes. We’re reminded by experts to use quotes sparingly. If we use too many quotes, it would appear that we’re unable to contribute something original in our paper. If you have more than three lengthy quotations in one page, you might be using quotes too much. Our sources tell us to consider the following rules when we use quotes:

1. “Enclose the word-for-word quote in quotation marks (“ ”) to show that the source author’s exact words appear in your paper.
2. “If you change anything about the original material to make it fit more neatly or clearly into your essay, use square brackets ([]) to indicate that material has been added or changed.
3. “Use ellipses (...) to show that material is left out.
4. “If the material you are quoting is longer than four lines, use block quote format, which means that you should not use quotation marks but instead indent the whole quoted bit one inch from the left margin so that it is clear what is your original work and what is quoted.”

Paraphrase

Your paraphrase is how you state the author’s ideas in your own words, which must convey the same meaning as the original author’s. A paraphrase is usually similar in length compared to the original material. You use your own words even as you include in your paraphrase the original names, figures, events, and other factual information from

the original author's material. Nevertheless, you may have the best paraphrase but you'll still have to cite your source within your text just the same.

Summary

A summary, which is much shorter than the original material, is your own restatement of the author's ideas but focusing on the major points in the material. As much as possible, avoid using quotes within a summary.

Whether or not you are employing quotation, paraphrasing, or summary in presenting the ideas of your source, you must always cite your sources.

I recommend strongly that you study the common style guides normally followed in academic writing, as indicated in the following matrix:

STYLE GUIDE	COMMONLY USED IN	URL
American Psychological Association (APA) Style Guide*	Commonly used in the social sciences	http://owl.english.purdue.edu
Modern Language Association (MLA) Style guide	Commonly used in the humanities and the arts	http://owl.english.purdue.edu
Council of Biology Editors (CBE) Style Guide	Commonly used in the sciences and mathematics	http://www.monrecc.edu
Turabian (Chicago) Style Guide**	Commonly used by students	http://www.ucberkeley.edu

*Similar to the APA style is what sometimes is known as the Harvard Style.

**The Turabian style, formally known as *A Manual for Writers of Term Papers, Theses, and Dissertations*, was developed by Kate Turabian, formerly dissertation secretary of the University of Chicago, specifically for students. It employs footnoting and endnoting as a technique of in-text and page citation.



Chapter 10

Mechanics of The Thesis Manuscript

The thesis proposal focuses on the first three chapters: introduction, review of the related literature, and the methodology, which is certainly just as well since you still have to conduct the research. So the proposal really is a plan. As all proposals go, therefore, you have to write your thesis proposal in the future tense.

Format

Most thesis proposals contain similar topics but may be arranged in different ways, depending on the preferences of your institution. The format or the general arrangement of content recommended in the previous editions of the book titled *How to Write a Thesis Proposal* is as follows:

1. INTRODUCTION
 - 1.1. Structure and Rationale of the Study
 - 1.2. The Research Problem
 - 1.3. Objectives of the Study

- 1.4. Importance of the Study
- 1.5. Limitations of the Study
- 1.6. Definition of Terms

2. REVIEW OF THE RELATED LITERATURE

NOTE: The organization of this chapter will depend on how you will classify the materials you include. Otherwise, the following are the major subheadings for this chapter.

- 2.1. The Literature (subheads according to the classification of variables)
- 2.2. Theoretical/Conceptual Framework
- 2.3. Hypotheses of the Study

3. METHODOLOGY

- 3.1. The Research Design
- 3.2. Variables of the Study
- 3.3. Respondents of the Study
- 3.4. Sampling Procedure
- 3.5. The Research Instrument
- 3.6. Procedures for Data Collection
- 3.7. Procedures for Data Analysis

4. BIBLIOGRAPHY

5. APPENDICES

Kumar (2005) suggested that the research proposal must contain the following components:

Introduction that includes brief review of the literature
Theoretical framework underpinning the study
Conceptual framework that constitutes the basis for your study
Objectives and research questions
Hypotheses to be tested

Study design
Setting for the study
Research instruments
Sampling design and sample size
Ethical issues
Data processing procedures
Proposed chapters of the report
Problems and limitations
Time frame

A more systematic format was suggested by Salkind (2006), as follows:

1. Introduction
 - 1.1. Problem Statement
 - 1.2. Rationale for the Research
 - 1.2.1. Statement of the Research Objectives
 - 1.3. Hypotheses
 - 1.4. Definition of Terms
 - 1.5. Summary, including re-statement of Problem
2. Review of Relevant Literature
 - 2.1. Importance of the Questions Being Asked
 - 2.2. Current Status of the Topic
 - 2.3. Relationship Between the Literature and Problem Statement
 - 2.4. Summary, including re-statement of relationship between important variables under consideration
3. Method
 - 3.1. Participants (include description of selection procedures)
 - 3.2. Research Design
 - 3.3. Data Collection Plan
 - 3.3.1. Operational definition
 - 3.3.2. Reliability and validity instruments
 - 3.3.3. Result of pilot studies
 - 3.4. Proposed Analysis of Data
 - 3.5. Results of the Data

4. Implications and Limitations
5. Appendices

What is now being recommended by this book is a reorganization or revision of the original format suggested in the book *How to Write a Thesis Proposal* to incorporate some of the suggestions of Kumar (2005) and Salkind (2006). It should be noted that these two authors were talking of the general research proposal rather than the specific thesis proposal, hence the slight difference in the nature of components and perhaps even organization.

Still, this book suggests that the most practical outline of the thesis proposal is as follows:

1. Introduction
 - 1.1. Background of the Study (must be brief)
 - 1.2. The Research Problem (perhaps expressed in a set of questions)
 - 1.3. The Research Objectives
 - 1.4. Hypotheses to be Tested
 - 1.5. Significance of the Study
 - 1.6. Limitations of the Study
 - 1.7. Definition of Terms
2. Review of the related Literature
NOTE: there are no standard side headings suggested here because how you will organize this chapter depends on your variables or the classification of studies reviewed. A suggested approach is to group the studies and discuss them according, thus:
 - 2.1. Studies in North America and Europe
 - 2.2. Studies in Asia
 - 2.3. Studies in the Philippines
 - 2.4. Synthesis of all the Studies Reviewed (indicating the flaws or gaps in the literature)

3. Methodology
 - 3.1. The Research Design
 - 3.2. Variables of the Study
 - 3.3. Respondents of the Study
 - 3.4. Sampling Procedures
 - 3.5. The Research Instrument
 - 3.6. Procedures for Data Collection
 - 3.7. Procedures for Data Analysis
4. Framework of the Study

There are times when your theoretical and conceptual frameworks may have to be discussed in much more detail than usual, which warrants that they be treated in a separate chapter. If you decide to do this, you simply have to provide much more detailed discussions, explaining more clearly the theory and how it relates to your study. Same thing is true with the conceptual and operational frameworks. If you do this, then the format that you will follow shall look like this:

- 4.1. Theoretical Framework
- 4.2. Conceptual Framework
- 4.3. Operational Framework

After the detailed discussions of these two components, provide a clear description of how these two are related to the hypotheses that you have introduced in the introduction of your thesis proposal. If you do not have to discuss your theoretical and conceptual frameworks in a separate chapter, include such discussion just after the synthesis of the review of literature you have prepared.

5. Bibliography
6. Appendices

In translating this format to a textual presentation, follow these suggestions:

1. Chapter title must be centered (below the chapter number) and typed in full capitals. If there is a need for a sub-center heading, only the first letter of the major words are capitalized.
2. Titles of major sections of the chapter are considered side headings. Type these side headings with the first letter of each major word capitalized, flush left.
3. Only the initial letter of the first word in a paragraph side heading should be capitalized. Underline or italicize the entire paragraph side heading.
4. The chapter head (and therefore the beginning of the chapter) must always start on a clean page. If there is space after the last line of the last paragraph in the chapter just finished, leave it. Go straight to the next page and start your new chapter there.

Preliminary Pages

Normally, a thesis proposal contains the following preliminary pages: title page, table of contents and list of figures. A completed research report (thesis), however, contains more items such as the following:

1. Title page
2. Biographical sketch (of author)
3. Dedication
4. Acknowledgment
5. Table of Contents
6. List of Tables
7. List of Figures

Appendices

The appendices contain all relevant materials that could not be included in the text. These include the questionnaire, additional tables, cover letters, and other such materials you have used in the conduct of the study.



Bibliography

- Ackoff, Russel L. and Fred E. Emery. (1972). On purposeful systems. Chicago: Aldine-Atherton.
- Alreck, Pamela L. and Robert B. Settle. (1985). The survey research handbook. Homewood, Illinois: Irwin Books.
- Aneshensel, Carol S. (2002). Theory-based data analysis for the social sciences. Thousand Oaks: Pine Forge Press.
- Babbie, Earl R. (1973). Survey research methods. Belmont, CA: Wadsworth Publishing Company, Inc.
- Bardens, Kenneth S. and Bruce B. Abbott. (2005). Research and design methods, a process approach. 6th Edition. Boston: McGraw-Hill.
- Best, John W. (1971). Research in education. 3rd Edition. Englewood Cliffs, NJ: Prentice-Hall, Inc.
- Bew, Angela. (2001). The nature of research (Inquiry in Academic Context). London: Routledge.
- Biggam, John. (2008). Succeeding with your master's dissertation. London: Open University Press.
- Birnbaum, Michael H. (2001). Introduction to behavioral research on the internet. Upper Saddle River, NJ: Prentice-Hall.
- Bogdan, Robert and Steven J. Taylor. (1975). Introduction to qualitative research methods. New York: John Wiley & Sons.
- Bogdan, Robert. (1972). Participant observation in organizational settings. Syracuse: Syracuse University Press.

- Burns, Robert B. (2000). Introduction to research methods. London: SAGE Publications.
- Campbell, Donald T. and Julian C. Stanley. (1963). Experimental and quasi-experimental designs for research. Chicago: Rand McNally College Publishing Company.
- Chua, Leonardo A. (1984). A guide in preparing a research proposal. College, Laguna: UPLB-CA Publications.
- Content analysis. Retrieved from: <http://www.ischool.utexas.edu/~palmquist/courses/content.html>
- Creswell, John W. (2003). Research design (qualitative, quantitative, and mixed methods approaches). 2nd edition. Thousand Oaks: SAGE Publications.
- De Vaus, David. (2006). SAGE benchmarks in social research methods (Research Design, Vols. I-IV). London: SAGE Publications.
- Dillman, Don A. (1978). Mail and telephone surveys. New York: John Wiley & Sons.
- Douglas, Jack D. (1976). Investigate social research. Beverly Hills: SAGE Publications.
- Fitt, M.H.; A.E. Walker; and H.M. Leary. (2009). Assessing the quality of doctoral dissertation literature reviews in instructional technology. Paper presented at the Annual Meeting of the American Educational Research Association, San Diego, CA. Retrieved from <http://digitalcommons.usu.edu/cgi/viewcontent.cgi.3/26/2012>.
- Gravetter, Frederick J. and Lori-Ann B. Forzano. (2003). Research methods for the behavioral sciences. Australia: Thomson.
- Guba, Egon G. (1978). Toward a methodology for naturalistic inquiry. Los Angeles: University of California Center for the Study of Evaluation.
- Hall, A.D. and R.E. Fagen. (1968). Definition of system. In Walter Buckley (Editor), *Modern systems research for the behavioral scientist* (a sourcebook), Aldine Publishing Co., Chicago, pp. 81-92.

- Heinich, Robert; Michael H. Molenda; and James D. Russell. (1982). *Instructional media and the new technologies of instruction*. New York: John Wiley & Sons.
- Jackson, Sherri L. (2006). *Research methods and statistics, a critical thinking approach*. 2nd Edition. Australia: Thomson.
- Kelly, Anthony E.; Richard A. Lesh; and John Y. Back. (2008). *Handbook of design research methods in education*. New York: Routledge.
- Kerlinger, Fred N. (1973). *Foundations of behavioral research*. 2nd Edition. New York: Holt, Rinehart and Winston, Inc.
- Kidder, Louise H. (1981). *Research methods in social relations*. New York: Holt, Rinehart and Winston, Inc.
- Krathwohl, David R. (1977). *How to prepare a research proposal*. 2nd Edition. Syracuse: Syracuse University Press.
- Kumar, Rangit. (2005). *Research methodology, A step-by-step guide for beginners*. London: SAGE Publications.
- Lammers, William J. and Pietro Badia. (2005). *Fundamentals of behavioral research*. Australia: Thomson.
- Leedy, Paul D. and Jeanne Ellis Ormrod. (2005). *Practical research, planning and design*. 8th Edition. Columbus, Ohio: Merrill/Prentice-Hall.
- Leslie, Larry Z. (2010). *Communication research methods in postmodern culture, a revisionist approach*. Boston: Allyn & Bacon.
- Librero, Felix. (1992). *Scientific information and the rice scientist*. Los Baños: International Rice Research Institute.
- Librero, Felix. (1985). *Problematique analysis: a methodology for evaluating communication systems*. Inaugural Lecture, Ayala Professorial Chair in Development Communication, U.P. Los Baños.

- Librero, Felix. (1983, 1981, 1980). Problematique analysis. (Originally a draft review of literature for PhD dissertation, Indiana University, 1980; mimeographed handout, 1981; and mimeographed booklet, Department of Development Communication, UPLB-CA, 1983.). Department of Development Communication, UPLB-CA, College, Laguna, Philippines.
- Linstone, Harold A. and Murray Turoff. (1975). *The DELPHI method: Techniques and application*. Reading, MA: Addison-Wesley Publishing Co.
- List, Dennis. (2005). Content analysis. Retrieved from: <http://www.audiencedialogue.net/kya16a.html>
- Lynch, Frank. (1979). *How to make a social survey, interview schedule*. Bangkok: The Agricultural Development Council, Inc.
- Manheim, Henry L. (1977). *Sociological research: Philosophy and methods*. Homewood, IL: The Dorsey Press.
- McBurney, Donald H. and Theresa L. White. (2004). *Research methods*. 6th Edition. Australia: Thomson.
- Mercado, Cesar M. nd. *The conduct of social science research*. Quezon City: UP Institute of Mass Communication.
- Merton, Robert K. (1973). *The sociology of science*. Chicago: the University of Chicago Press.
- Middle East Technical University, Academic Writing Centre. (nd). Writing a review of literature. Retrieved from http://www.awc.metu.edu.tr/handouts/Writing_a_Review_of_Literature.pdf 3/26/2012.
- Mitchell, Mark L. and Janina M. Jolly. (2004). *Research design explained*. 5th Edition. Australia: Thomson.
- Mitton, Roger. (1982). *Practical research in distance teaching*. Cambridge: International Extension College.
- Molenda, Michael H. and Anthony diPaolo. (1979). *An analysis of problems and possibilities of the audiovisual general department*. A report prepared for the USAID/ Cairo, June 18th.
- Murray, Rowena. (2002). *How to write a thesis*. London: Open University Press.

- Olson, Sheldon R. (1976). Ideas and data. Homewood, IL: The Dorsey Press.
- Parel, Cristina P. et al. (1966). Introduction to statistical methods. Manila: Macaraig Publishing Co.
- Parker, Ian. Discursive practice (analysis, context, and action in critical research). Retrieved from: http://www.discourseunit.com/publications_pages/parker_papers/2004IJGPDiscoursePractive.pdf
- Pittenger, David J. (2003). Behavioral research, design and analysis. Boston: McGraw-Hill.
- Punch, Keith F. (2006). Developing effective research proposals. 2nd Edition. London: SAGE Publications.
- Rea, Louis M. and Richard A. Parker. (2005). Designing and conducting survey research, a comprehensive guide. 3rd Edition. San Francisco, CA: Jossey-Bass.
- Salkind, Neil J. (2006). Exploring research. 6th Edition. Upper Saddle River, NJ: Pearson Education, Inc.
- Shuttleworth, Marlyn. (2009). What is a literature review? Retrieved from <http://www.experiment-resources.com/what-is-a-literature-review.html> 3/26/2012.
- Schmidt, Charles F. (nd). Some S-R theory. Retrieved from http://www-rci.rutgewrs.edu/~cfs/305_html/SR_Theory.html 3/27/2012.
- Suppes, Patrick. (1977). A survey of contemporary learning theories. In Butts and Hinukka (eds.), Foundational Problems in the Special Sciences, Reidel Publishing Company, Dorcdrecht, Holland, pp. 217-230. Retrieved from <http://suppes-corpus.stanford.edu/articles/psych/183.pdf> 3/27/2012.
- Taylor, Dena and Margaret Proctor. (nd). The literature review: a few tips on conducting it. Retrieved from <http://www.writing.utoronto.ca/images/stories/Documents/literature-review.pdf> 3/26/2012.
- Tepke, Brent E. (1980). Business statistics. New York: Barnes and Noble Books.
- Thody, Angela. (2006). Writing and presenting research. London: SAGE Publications.

- Triola, Mario F. (2008). *Elementary statistics*. 11th Edition. Upper Saddle River, NJ: Pearson Education, Inc.
- University of Chicago Press Staff. (1982). *The Chicago manual of style*. 13th Edition. Chicago: University of Chicago Press.
- Van Dalen, Deobold B. (1979). *Understanding educational research*. 4th Edition. New York: McGraw-Hill Book Co., Inc.
- Wamsler, Christine. (2009). *Operational framework for integrating risk reduction and climate change adaptation into urban development*. Manchester: The Global Urban Research Centre. Retrieved from http://www.sed.manchester.ac.uk/research/gurc/documents/GURC_wp3.pdf. 3/24/2012.
- Walliman, Nicholas. (2006). *Social research methods*. London: SAGE Publications.
- Wikipedia. (nd). Literature review. Retrieved from http://en.wikipedia.org/wiki/Literature_review 3/26/2012.
- Wikipedia. (nd). Illustration. Retrieved from <http://en.wikipedia.org/wiki/Illustration>. 3/26/2012.
- Williams, Frederick. (1968). *Reasoning with statistics*. New York: Holt, Rinehart and Winston, Inc.
- Yin, Robert K. (2006). Research designs. In David de Vaus (Ed.), *Research methods* (Research Design, Volume 1), SAGE Publications, London, pp. 5-83.

PART III

Appendices



Appendix A

Sample Literature Review

Prosocial Television Research*

In recent years, social scientists have conducted a number of studies determining the effects of television on the behavior of both children and adults. These studies dealt with both positive and negative attitudes and behavior as a result of television viewing. In a number of laboratory and field experiments, researchers in North America have found that television programs designed to emphasize positive attitudes and behavior, aptly termed prosocial television, have tended to affect the viewer's attitudes and behavior positively.

This article reviews four experiments on prosocial television in Canada and the United States. Hopefully, this article will be able to show some possible areas of concern for research under Philippine conditions.

*Reproduced from DEVCOM QUARTERLY (1983), vol. 1, no. 2, pp. 4-18.

The experiments

Goldberg and Gorn (1974) attempted to determine whether or not television could change children's attitudes in a prosocial direction. The basic question was: would a series of inserts into "Sesame Street" produce the desired effects of creating more favorable attitudes towards children of several races in Canada and towards French-Canadian people and their culture?

The researchers developed inserts that depicted other racial groups in a purely ethnic, non-integrative setting. They predicted that the inserts would be effective in producing a more favorable response to non-white children for two reasons. First, the integrated and non-integrated inserts were produced in an attractive manner. Second, the inserts served to increase the exposure of the white children to other racial groups.

In the first insert, a French-Canadian child speaking French appeared. The researchers observed that the children viewing the program paid more attention to what they saw than what they heard. The French-Canadian child was liked very much by the children when he did not speak French. However, the children did not like him less either when they recognized him as a French-Canadian speaking an unfamiliar language. In the second insert, the children were exposed to a group of non-whites in an ethnic setting, and a mixed group interacting in a familiar setting. In both cases, the children preferred to play with non-whites rather than whites after exposure to the program.

Goldberg and Gorn, therefore, concluded that minimal television exposure can produce very clear-cut short-term attitude change towards televised children of other racial and ethnic groups.

In the Goldberg-Gorn study, environmental factors were not considered. This was picked up by Friederick, Stein, and Susman (1975) who conducted a laboratory experiment to determine the effects of prosocial television and environmental conditions on preschool children. They were interested to find out whether or not a television program designed to enhance personal, social and emotional development had a positive effect on children's behavior and what elements in the environment would contribute with exposure to television to produce the greatest positive effects.

Their respondents were children, three to five years old, who were enrolled in Head Start Programs for Inner City Children. There were a total of 13 classrooms. Three classrooms were assigned to one of four experimental treatments except for the fourth treatment where there were four classrooms assigned. In the first treatment, the children were exposed to a neutral film plus irrelevant play materials in the classroom. The children in the second treatment were exposed to prosocial television plus irrelevant play materials in the classroom. The third group was exposed to prosocial television plus relevant play materials in the classroom. Finally, the fourth group was exposed to prosocial television plus a teacher who rehearsed the children on the content of the program they viewed.

Twenty episodes of the program "Mister Rogers' Neighborhood" or neutral film were used in the experiments under two classroom conditions, namely: high and low classroom structure. High classroom structure was operationalized as having harsh disciplinary procedures and lack of warmth of the teacher, while the low classroom structure was operationalized as having high level for warmth from the teacher and non-punitive atmosphere.

The variables that the researchers measured were positive social interaction with peers, verbal interaction with peers, imaginative play and non-verbal interaction with peers.

The results of the experiment showed that for positive social interaction with peers, prosocial television with relevant play materials and a teacher had the highest effect upon the children under high classroom structure, while prosocial television with related play materials had high effect under low classroom structure condition and prosocial television and related materials had the lowest effect. As for verbal interaction with peers, both prosocial television with teacher and prosocial television with related materials had higher effect than the other treatments under low classroom structure condition. On the other hand, the combination of prosocial television and teacher was the most effective in imaginative play. This was followed by prosocial television with related materials. There were no consistent effects in the non-verbal interaction with peers. Prosocial television by itself did not differ with the neutral treatment, but it had a slight trend towards increased imaginative play.

The general effects of prosocial television with related materials was affected by classroom structure. Under the high classroom condition, this treatment was found most effective when a teacher was present to direct rehearsal or provide instruction. In the low classroom condition, additional materials designed to stimulate rehearsal of the program content were associated with prosocial behavior. Children under this condition had high levels of positive interaction with peers and imaginative play compared to those under neutral conditions. Prosocial television with teacher training had the most consistent and clear cut effects on positive social interaction with peers and imaginative play.

Over-all, the effects of prosocial television were more pronounced in the low structure condition, while high level

structure reduced the possibility that television programs would affect positive social behavior among peers.

In another experiment with children as respondents, Poulos, Rubinstein, and Liebert (1975) assessed the effects of three television programs on positive social behavior. Respondents of the experiment were 30 children whose ages ranged from six to eight years. There were 15 boys and 15 girls who were first graders in a predominantly white middle class public school.

One group was exposed to a prosocial episode of the program "Lassie" where the story was about Lassie's efforts to hide her puppy so that it will not be given away. The story was climaxed when the puppy slipped into a mining shaft and was rescued by Jeff, a human character in the program, at the risk of his life. Another group was exposed to another episode of "Lassie", but this time, the program was neutral. It dramatized Jeff's attempt to avoid taking violin lessons and the episode was devoid of any example of a human being helping a dog. However, the animal was depicted in a positive way. The third group was exposed to one episode of "The Brady Bunch" program where the youngest of the Brady children was doing all he could to be important by trying to set a record for time spent on a seesaw. These episodes provided a measure of the children's willingness to help after exposure to a popular program that showed positive interpersonal family encounters, but not cues pertained to either human or canine heroism.

At the experimental room, each child first viewed the appropriate program alone. Then he/she was made to play a game where he/she could earn points by pressing a button. Each child was also asked to monitor the care of puppies in a distant dog kennel by listening to earphones. If the dogs barked, he was to press the "help" button and earn points. Outside the experimental room, a timer recorded the number of seconds the "help" button was pressed. The

respondent was also monitored from the adjoining room by video cameras with split-screen videotape to show the child's facial expression only while viewing the program. A very significant part of the experiment procedure was the control of the sources of bias done in two ways. First, the raters saw only the facial expression of the child through split-screen videotapes. Second, the two raters scored the child's attention on the program from monitors located in different rooms which maximized independence of rating.

Results of the experiment showed that the prosocial program was attended significantly by both sexes. It may also be interesting to point out another observation. Those who viewed the prosocial "Lassie" episode had a different pattern of attention on the upward trend, while those who viewed the neutral episode had a downward trend of attention pattern.

Findings indicate that the respondents who saw the prosocial "Lassie" program pressed the "help" button significantly more than those who viewed the neutral "Brady Bunch" program. The last two programs did not differ from one another.

In an effort to find whether or not the effects of prosocial television on children also holds true to adults, Loye (1975) conducted a field experiment to determine the prosocial effects of television on adults. He was specifically interested in finding out the kinds of effects television had on the psychosocial functioning of the individuals.

The respondents of the experiment were 260 couples selected from 1,400 volunteers in the Los Angeles area. The respondents were dominantly Caucasian, more affluent and educated than what Loye called the American norm, but at the same time much more typical of the American viewer. Respondents' ages ranged from 20 to 70.

The respondents were assigned to five experimental treatments composed of existing television programs that were classified according to the following categories: high in helpful or prosocial behavior; high in hurtful or violent behavior; neutral or so-called light entertainment; mixture of both prosocial and violent behavior; and neutral. The classification of programs was done by psychiatrists, psychologists, parents and other groups who watched a total of 149 programs through cable television across the board (Monday to Sunday) in the third week of October 1974. The programs were viewed between 7 pm and 11 pm. Before and after viewing the programs, they were assigned to, the respondents filled out either a program report or a mood checklist.

The procedure was that the husband viewed the program while the wife was a participant observer who recorded all the behaviors of her husband all throughout the week on a “plus” and “minus” behavioral scale specifically designed for this experiment.

Results of the study showed that those who viewed the prosocial programs like the “Waltons” during the week showed a decline in their aggressive mood, and those who viewed the violent programs like “Hawaii Five-O” maintained an aggressive mood. All the respondents had identical levels of aggressiveness at the start of the experiment.

Some loopholes

While providing identical indications that prosocial television does tend to affect the behavior of both children and adults in a positive way, the methodologies followed by the researchers differed in significant ways that could have had some effects on their results. The experiments

of Poulos et al. and Friedrich were laboratory experiments and, therefore, had some amount of control over variables. Particularly, the study of Poulos and her colleagues attempted to control a likely source of bias which the three other studies did not consider. On the other hand, the field experiments conducted by Loye, Goldberg and Gorn had taken other possible factors into consideration although not necessarily measuring their effects.

Except for Loye, the researchers failed to establish some sort of baseline reference point. In other words, there is a possibility that what they may have found could have been the cumulative effects of the experiences of the respondents and their psychological state at the time of experimentation. Therefore, it is difficult to say just how much effect of prosocial television was. In any case, the studies arrived at significant results and the researchers are agreeable that prosocial television does have an effect on the positive behavior of viewers. Just how much or to what degree this effect is, was not established.

The significance of these findings cannot be overemphasized. The power of television as a precursor of social change and value is underscored by these findings. More prosocial programs on the airlines could have large positive social effects. This might also hold true with instructional television. It could be possible that children might learn more effectively if the subject matter were treated the same way as those in commercial television programs, as shown by the experimental results on "Sesame Street" and "Mister Rogers' Neighborhood." However, there is still a need for more data.

References

- Friedrick, L. K.; A. H. Stein; and E. Susman. (1975). *The effects of prosocial television and environmental conditions on preschool children*. Paper presented at the Meeting of American Psychological Association, Chicago, September, 1975. 16 pp.
- Goldberg, M.E. and G. J. Gorn. (1975). *Television's impact: changing children's attitudes in prosocial direction*. ERIC. 10 pp.
- Loye, D. (1975). *Mass entertainment and human survival: television's potential for prosocial effects on adults*. Department of Psychiatry, University of California, Los Angeles. 30 pp.
- Poulos, R. W.; E. A. Rubinstein; and R. M. Liebert. (1975). *Positive social learning*. *Journal of Communication* (Autumn), 254(4): 90-97.



Appendix B

Outline for Evaluating a Research Report

Outline for Evaluating a Research Report

What are the objectives of the study?

What are the research questions and research hypotheses?

You may have to treat the Null Hypothesis (H_0) as a research question, not hypothesis.

1. Identify the questions, identify the hypotheses.
2. State briefly the sources (bases) of the questions and hypotheses.
3. Determine whether or not the questions are answerable and the hypotheses testable; give the bases for your answer.

*Suggested points to be highlighted in reviewing research reports based on experiments.

What are the independent variables?

1. Identify the independent variables.
2. Classify independent variables as “manipulation” or “classification”.
3. State the values of each independent variable.

What are the dependent variables?

What is the population frame?

1. Identify the population.
2. Describe method of obtaining samples.
3. Describe the method of assigning respondents to conditions.

How were extraneous variables controlled?

1. Describe the procedures designed to control extraneous variables.
2. Identify what appear to you to be uncontrolled extraneous variables.
3. Describe a method of controlling those uncontrolled variables.

What were the methods of statistical analysis employed?

1. Determine the statistical tools employed.
2. Determine whether or not the statistical tools were used correctly.

What were the results of the study?

1. State the results in terms of difference between means, correlation coefficients, etc., and probability values.
2. Determine whether or not the results supported the hypotheses.
3. Evaluate the appropriateness of the author’s interpretation of the results.

Appendix C

Sample Questionnaire

(for a hypothetical study conducted in a hypothetical College)

Media Utilization Pattern Among
Faculty Members of the Laguna Open College

QUESTIONNAIRE

Instructions

1. Please complete this questionnaire as soon as you can. When you are finished, please send it back using the attached self-addressed envelop.
2. No individual respondent will be identified in the report of this study.

The following questions ask for specific information about your teaching career, use of educational media in your teaching practice, and your opinions and suggestions about the use of educational media in the Open College. Please answer all questions as best as you can.

Thank you.

1. Including this year, how many years have you been teaching? (Elementary, High School, College/University)

(Please check appropriate space.)

- 1 - 5 YEARS
- 6 - 10 YEARS
- 11 - 15 YEARS
- 16 - 20 YEARS
- 21 YEARS AND OVER

2. Please tick your academic rank.

- ASSISTANT PROFESSOR
- ASSOCIATE PROFESSOR
- PROFESSOR

3. In what department in the Open College do you teach?

(If you teach in more than one department, please tick the one you consider your primary department.)

- ART DEPARTMENT
- COUNSELLING AND GUIDANCE
- ADMINISTRATION AND ADMINISTRATIVE STUDIES
- EDUCATIONAL PSYCHOLOGY
- HISTORY, PHILOSOPHY AND COMPARATIVE EDUCATION
- INSTRUCTIONAL SYSTEMS TECHNOLOGY
- SCIENCE, SOCIAL STUDIES AND MATH
- SPECIAL EDUCATION
- CURRICULUM AND INSTRUCTION
- VOCATIONAL EDUCATION

4. How familiar are you with the operation of each of the following pieces of educational media equipment?

Please tick one answer for each piece of equipment listed.

Category/ Equipment	Have never operated	Find difficult to operate	Can satis- factorily operate
SOUND SLIDE PROJECTOR	_____	_____	_____
OVERHEAD PROJECTOR	_____	_____	_____
OPAQUE PROJECTOR	_____	_____	_____
VIDEOTAPE PLAYBACK MACHINE	_____	_____	_____
MULTIMEDIA PROJECTOR	_____	_____	_____
COMPUTER TERMINAL	_____	_____	_____
TABLE TOP COMPUTER	_____	_____	_____
LAPTOP COMPUTER	_____	_____	_____
TAB	_____	_____	_____
NETBOOK	_____	_____	_____
WIRELESS PHONE	_____	_____	_____
OTHERS (Specify) _____	_____	_____	_____
_____	_____	_____	_____
_____	_____	_____	_____

5. How many courses did you teach last semester?

Please list. (Exclude individualized research or reading course.)

<i>Course Title</i>	<i>Credit Hour</i>
_____	_____
_____	_____
_____	_____

6. During last semester, how frequently did you use any or all of the following media in your classes (in the classroom)?

(Please tick the space representing the number of times you used the corresponding medium in the courses you taught last semester. Please be as accurate as you can.)

Audiovisual Medium	0 Time	1-10 Times	11-20 Times	Over 20 Times
SOUND SLIDE PROJECTOR	_____	_____	_____	_____
OVERHEAD PROJECTOR	_____	_____	_____	_____
OPAQUE PROJECTOR	_____	_____	_____	_____
VIDEOTAPE PLAYBACK MACHINE	_____	_____	_____	_____
MULTIMEDIA PROJECTOR	_____	_____	_____	_____
COMPUTER TERMINAL	_____	_____	_____	_____
TABLE TOP COMPUTER	_____	_____	_____	_____
LAPTOP COMPUTER	_____	_____	_____	_____
TAB	_____	_____	_____	_____
NETBOOK	_____	_____	_____	_____
WIRELESS PHONE	_____	_____	_____	_____
OTHERS (Specify) _____	_____	_____	_____	_____
_____	_____	_____	_____	_____
_____	_____	_____	_____	_____

7. During last semester, what percentage of your class time you estimate you devoted to using what you consider the top five media in teaching your courses?

(Please rank order the top five media you used in teaching your courses last semester, and tick appropriate spaces for each.)

If you did not teach last semester, please tick this space.

Rank	Media	Percentage of Time Used				
		0 %	1-10 %	11-20 %	21-30 %	Over 30 %
___	SOUND SLIDE PROJECTOR	___	___	___	___	___
___	OVERHEAD PROJECTOR	___	___	___	___	___
___	OPAQUE PROJECTOR	___	___	___	___	___
___	VIDEOTAPE PLAYBACK MACHINE	___	___	___	___	___
___	MULTIMEDIA PROJECTOR	___	___	___	___	___
___	COMPUTER TERMINAL	___	___	___	___	___
___	TABLE TOP COMPUTER	___	___	___	___	___
___	LAPTOP COMPUTER	___	___	___	___	___
___	TAB	___	___	___	___	___
___	NETBOOK	___	___	___	___	___
___	WIRELESS PHONE	___	___	___	___	___
___	OTHERS (Specify) _____	___	___	___	___	___
	_____	___	___	___	___	___
	_____	___	___	___	___	___

8. During last semester, in teaching courses, what were the educational media you assigned most frequently to your students to view or listen to out-of-class study?

(Please rank order the top five educational media you most frequently assigned to students to view or listen to in out-of-class study. Designate the top rank as #1.)

<i>Rank</i>	<i>Educational Media</i>
_____	SOUND SLIDE PROJECTOR
_____	OVERHEAD PROJECTOR
_____	OPAQUE PROJECTOR
_____	VIDEOTAPE PLAYBACK MACHINE
_____	MULTIMEDIA PROJECTOR
_____	COMPUTER TERMINAL
_____	TABLE TOP COMPUTER
_____	LAPTOP COMPUTER
_____	TAB
_____	NETBOOK
_____	WIRELESS PHONE
_____	OTHERS (Specify) _____

9. In your general teaching practice, what are the top educational media, other than the chalkboard and whiteboard, you use most frequently?

(Please list the top five educational media you use most frequently according to rank.)

1. _____
2. _____
3. _____
4. _____
5. _____

10. How significant do you think were the contributions of educational media in the courses you taught last semester?

- EXTREMELY SIGNIFICANT
- MODERATELY SIGNIFICANT
- MINIMALLY SIGNIFICANT
- NOT SIGNIFICANT

11. How do you rate yourself in terms of your proficiency in using the following educational media in your teaching practice?

(Please tick appropriate space.)

Media	Highly Proficient	Moderately Proficient	Minimally Proficient	Not Proficient
SOUND SLIDE PROJECTOR	<input type="checkbox"/>	<input type="checkbox"/>	<input type="checkbox"/>	<input type="checkbox"/>
OVERHEAD PROJECTOR	<input type="checkbox"/>	<input type="checkbox"/>	<input type="checkbox"/>	<input type="checkbox"/>
OPAQUE PROJECTOR	<input type="checkbox"/>	<input type="checkbox"/>	<input type="checkbox"/>	<input type="checkbox"/>
VIDEOTAPE PLAYBACK MACHINE	<input type="checkbox"/>	<input type="checkbox"/>	<input type="checkbox"/>	<input type="checkbox"/>
MULTIMEDIA PROJECTOR	<input type="checkbox"/>	<input type="checkbox"/>	<input type="checkbox"/>	<input type="checkbox"/>
COMPUTER TERMINAL	<input type="checkbox"/>	<input type="checkbox"/>	<input type="checkbox"/>	<input type="checkbox"/>
TABLE TOP COMPUTER	<input type="checkbox"/>	<input type="checkbox"/>	<input type="checkbox"/>	<input type="checkbox"/>
LAPTOP COMPUTER	<input type="checkbox"/>	<input type="checkbox"/>	<input type="checkbox"/>	<input type="checkbox"/>
TAB	<input type="checkbox"/>	<input type="checkbox"/>	<input type="checkbox"/>	<input type="checkbox"/>
NETBOOK	<input type="checkbox"/>	<input type="checkbox"/>	<input type="checkbox"/>	<input type="checkbox"/>
WIRELESS PHONE	<input type="checkbox"/>	<input type="checkbox"/>	<input type="checkbox"/>	<input type="checkbox"/>
OTHERS (Specify) _____	<input type="checkbox"/>	<input type="checkbox"/>	<input type="checkbox"/>	<input type="checkbox"/>
_____	<input type="checkbox"/>	<input type="checkbox"/>	<input type="checkbox"/>	<input type="checkbox"/>
_____	<input type="checkbox"/>	<input type="checkbox"/>	<input type="checkbox"/>	<input type="checkbox"/>

12. Below is a list of purposes for which educational media are used.

(Please rank order them in terms of your own purposes in using educational media in your teaching practice.)

Rank Purpose

- ___ TO PRESENT ESSENTIAL INFORMATION AND/OR CLARIFY CONCEPTS.
- ___ TO CHANGE AND/OR STRENGTHEN ATTITUDES.
- ___ TO DEMONSTRATE SKILLS AND TECHNIQUES.
- ___ TO STIMULATE INTEREST.
- ___ TO RAISE ISSUES/PROBLEMS/QUESTIONS AND ENCOURAGE DISCUSSION.

13. Below is a list of problems educators have experienced in using educational media. Please respond to the statements in terms of your own experiences in using educational media by using the following scale:

- 1 = STRONGLY AGREE
- 2 = AGREE
- 3 = UNDECIDED
- 4 = DISAGREE
- 5 = STRONGLY DISAGREE

(Please encircle the number, to the left of the statement, that most accurately reflect your response to the statement.)

1 2 3 4 5 I DO NOT HAVE ENOUGH TIME TO ADEQUATELY SELECT, LOCATE AND PREVIEW COMMERCIALY PRODUCED MATERIALS.

1 2 3 4 5 IT IS DIFFICULT TO INTEGRATE EDUCATIONAL MEDIA IN MY COURSE PLAN.

- 1 2 3 4 5 I DO NOT HAVE ENOUGH INFORMATION TO DETERMINE WHAT MATERIALS ARE MOST APPROPRIATE FOR MY CLASS.
- 1 2 3 4 5 I DO NOT HAVE ENOUGH TIME TO DO ALL THE BASIC TEACHING I SHOULD, LET ALONE USE EDUCATIONAL MEDIA.
- 1 2 3 4 5 SEARCHES FOR MATERIALS IN MY SPECIFIC CONTENT AREA REVEAL FEW SUITABLE MATERIALS.
- 1 2 3 4 5 THERE IS TOO MUCH "RED TAPE" IN ORDERING MATERIALS AND SCHEDULING EQUIPMENT.
- 1 2 3 4 5 STUDENTS LOOK ON EDUCATIONAL MEDIA LESSONS AS "ENTERTAINMENT" AND DO NOT "STUDY" THE MATERIALS PRESENTED.
- 1 2 3 4 5 EDUCATIONAL MEDIA ARE TOO EXPENSIVE FOR THE RESULTS OBTAINED.
- 1 2 3 4 5 EDUCATIONAL MEDIA ARE NOT FREQUENTLY AVAILABLE WHEN I NEED THEM.
- 1 2 3 4 5 I DO NOT HAVE ENOUGH TRAINING TO USE EFFECTIVELY SELECTED EDUCATIONAL MEDIA.
- 1 2 3 4 5 THE ADMINISTRATION DOES NOT SEEM TO BE INTERESTED IN THE USE OF EDUCATIONAL MEDIA.
- 1 2 3 4 5 THE BUDGET FOR EDUCATIONAL MEDIA IS NOT SUFFICIENT TO PROVIDE FOR MY NEEDS.
- 1 2 3 4 5 I HAVE DIFFICULTY USING EDUCATIONAL MEDIA.

14. What plans do you have for using each of the following educational media in the next two semesters?

(Please tick appropriate space for each medium.)

Medium	Have not used and		Continue present level of use	Expand present level of use
	No plans to try	Plan to try		
SOUND SLIDE PROJECTOR	___	___	___	___
OVERHEAD PROJECTOR	___	___	___	___
OPAQUE PROJECTOR	___	___	___	___
VIDEOTAPE PLAYBACK MACHINE	___	___	___	___
MULTIMEDIA PROJECTOR	___	___	___	___
COMPUTER TERMINAL	___	___	___	___
TABLE TOP COMPUTER	___	___	___	___
LAPTOP COMPUTER	___	___	___	___
TAB	___	___	___	___
NETBOOK	___	___	___	___
WIRELESS PHONE	___	___	___	___
SIMULATIONS & GAMES	___	___	___	___
VIDEO GAMES	___	___	___	___
TELEVISION	___	___	___	___
RADIO	___	___	___	___

15. During your teaching tenure, have you planned and produced, or had someone else produce, educational media materials for your class?

___ YES ___ NO

16. If yes, which of the following materials have you either planned and produced, or had someone else planned and produce for you, for your classes?

(Please check appropriate space.)

Material	How many were produced?					
	None	1-5	6-10	11-15	16-20	>20
COMPUTER PROGRAMS	—	—	—	—	—	—
POWERPOINT PRESENTATIONS	—	—	—	—	—	—
COMPUTER-BASED GAMES AND SIMULATIONS	—	—	—	—	—	—
MOTION PICTURES	—	—	—	—	—	—
VIDEO RECORDINGS	—	—	—	—	—	—
OVERHEAD TRANSPARENCIES	—	—	—	—	—	—
SLIDE SETS WITH SOUND	—	—	—	—	—	—
SLIDE SETS WITHOUT SOUND	—	—	—	—	—	—
FLAT PICTURES	—	—	—	—	—	—
AUDIO TAPE RECORDINGS	—	—	—	—	—	—
SELF INSTRUCTIONAL MATERIALS	—	—	—	—	—	—
CHARTS, GRAPHS, ILLUSTRATIONS	—	—	—	—	—	—
EXHIBITS, DISPLAYS	—	—	—	—	—	—
MODELS	—	—	—	—	—	—
OTHERS (Specify) _____	—	—	—	—	—	—
_____	—	—	—	—	—	—
_____	—	—	—	—	—	—

17. How do you rate your school/ department for producing the following educational media for your instructional use?

(Please tick appropriate space.)

Material	Very Ade-quate	Ade-quate	Mini-mally Ade-quate	Inade-quate
COMPUTER PROGRAMS	_____	_____	_____	_____
POWERPOINT PRESENTATIONS	_____	_____	_____	_____
COMPUTER-BASED GAMES AND SIMULATIONS	_____	_____	_____	_____
MOTION PICTURES	_____	_____	_____	_____
VIDEO RECORDINGS	_____	_____	_____	_____
OVERHEAD TRANSPARENCIES	_____	_____	_____	_____
SLIDE SETS WITH SOUNDTRACK	_____	_____	_____	_____
SLIDE SETS WITHOUT SOUNDTRACK	_____	_____	_____	_____
FILMSTRIPS	_____	_____	_____	_____
FLAT PICTURES	_____	_____	_____	_____
AUDIOTAPE RECORDINGS	_____	_____	_____	_____
SELF INSTRUCTIONAL MATERIALS	_____	_____	_____	_____
CHARTS, GRAPHS, ILLUSTRATIONS	_____	_____	_____	_____
EXHIBITS, DISPLAYS, ETC.	_____	_____	_____	_____
MODELS	_____	_____	_____	_____
OTHERS (Specify) _____	_____	_____	_____	_____
_____	_____	_____	_____	_____
_____	_____	_____	_____	_____

18. In your judgment, are the classrooms where you teach adequately or inadequately set up for use of educational media?

(Please tick appropriate space.)

- VERY ADEQUATE
 ADEQUATE
 MINIMALLY ADEQUATE
 INADEQUATE

19. If inadequate, what do you see as the problem?

(Please list.)

- a. _____
 b. _____
 c. _____
 d. _____
 e. _____

20. Below is a list of possible production priorities for faculty members.

(Please rank order them according to your own priorities.)

<i>Rank</i>	<i>Material</i>
_____	COMPUTER PROGRAMS
_____	POWERPOINT PRESENTATIONS
_____	COMPUTER-BASED GAMES AND SIMULATIONS
_____	MOTION PICTURES
_____	VIDEO RECORDINGS
_____	OVERHEAD TRANSPARENCIES
_____	SLIDE SETS WITH SOUNDTRACK
_____	SLIDE SETS WITHOUT SOUNDTRACK
_____	FILMSTRIPS
_____	FLAT PICTURES
_____	AUDIOTAPE RECORDINGS
_____	SELF INSTRUCTIONAL MATERIALS
_____	CHARTS, GRAPHS, ILLUSTRATIONS
_____	EXHIBITS, DISPLAYS, ETC.
_____	MODELS
_____	OTHERS (Specify) _____

21. Are you interested in participating in an in-service training program to learn more skills in using educational media?

(Please tick as applicable.)

- VERY INTERESTED
- MODERATELY INTERESTED
- SLIGHTLY INTERESTED
- NOT INTERESTED

22. Which of the following possible areas do you think are priority training for yourself?

(Please rank order the top three training areas according to your own priorities.)

- | <i>Rank</i> | <i>Training Area</i> |
|--------------------------|--|
| <input type="checkbox"/> | EDUCATIONAL MEDIA EQUIPMENT OPERATION AND MAINTENANCE |
| <input type="checkbox"/> | UTILIZATION OF EDUCATIONAL MEDIA |
| <input type="checkbox"/> | PRODUCTION OF SOUND SLIDE SETS |
| <input type="checkbox"/> | BASIC PHOTOGRAPHY |
| <input type="checkbox"/> | BASIC VIDEO AND MOTION PICTURE PHOTOGRAPHY |
| <input type="checkbox"/> | NON-PHOTOGRAPHIC PRODUCTION OF OVERHEAD TRANSPARENCIES |
| <input type="checkbox"/> | PRODUCTION OF GRAPHIC MATERIALS |
| <input type="checkbox"/> | TELEVISION PROGRAM PRODUCTION |
| <input type="checkbox"/> | PRODUCTION OF NON-PROJECTED SIMULATION AND GAMES |
| <input type="checkbox"/> | PRODUCTION OF VIDEO GAMES |
| <input type="checkbox"/> | PRODUCTION OF COMPUTER PROGRAMS |
| <input type="checkbox"/> | PRODUCTION OF GAMES AND SIMULATIONS |
| <input type="checkbox"/> | PRODUCTION OF POWERPOINT PRESENTATIONS |
| <input type="checkbox"/> | OTHERS (Please specify) _____ |
| | _____ |
| | _____ |

23. In your best judgment, which of the following materials do you think will be the most in demand among the faculty members of your department in the next five years?

(Please rank order the top five you think will be in most demand.)

<i>Rank</i>	<i>Educational Material</i>
___	COMPUTER GAMES AND SIMULATIONS
___	VIDEO GAMES
___	INTERNET-BASED GAMES AND SIMULATIONS
___	DIGITAL PICTURES
___	VIDEOCASSETTES
___	VIDEODISCS
___	COMPUTER ASSISTED INSTRUCTION PROGRAMS
___	FILMSTRIPS
___	8MM FILMS
___	16MM FILMS
___	PODCASTS
___	VODCASTS
___	SOUND SLIDE SETS
___	OVERHEAD TRANSPARENCIES
___	SELF INSTRUCTIONAL MATERIALS
___	MOUNTED FLAT PICTURES
___	TELEVISION PROGRAMS
___	MICRO-COMPUTER PROGRAMS
___	RADIO PROGRAMS
___	OTHERS (Please specify) _____

24. Considering the area of educational materials, equipment, facilities, and services in your department/college, what do you see as the three areas which mostly need improvement?

(Please rank order the top three improvements you think are most needed, with #1 as most needed.)

<i>Rank</i>	<i>Possible Improvement</i>
___	IMPROVE AIR CONDITIONING SYSTEM IN CLASSROOMS
___	IMPROVE ROOM DARKENING BLINDS AND CURTAINS IN CLASSROOMS
___	ACQUIRE NEW EDUCATIONAL MEDIA EQUIPMENT
___	PROVIDE BETTER PROGRAM ASSISTANCE TO FACULTY REGARDING PLANNING, DESIGNING, AND PRODUCING MATERIALS
___	DEVELOP BETTER CATALOGING SYSTEM FOR EDUCATIONAL MEDIA
___	IMPROVE PRODUCTION FACILITIES
___	ARRANGE FOR REGULAR MEDIA DEMONSTRATIONS AND WORKSHOPS FOR FACULTY MEMBERS
___	PROVIDE MORE BUDGET ALLOCATION FOR EDUCATIONAL MEDIA
___	INSTITUTE BETTER EDUCATIONAL MEDIA SERVICE COORDINATION

THANK YOU FOR YOUR COOPERATION.

Appendix D

Towards a Methodology for Problematique Analysis*

By

Felix Librero

Abstract

Problematique analysis is a naturalistic approach for describing the structure of problems that exist in communication systems. The basic purpose of this approach is to identify the problem rather than the solution. In the process, therefore, the evaluator employing problematique analysis identifies the factors that influence the system, shows the hierarchical relationships of these factors and traces the root causes of the problems of the system. Founded on systems theory, problematique analysis assumes that a communication system: 1) is purposive; 2) exists in a hierarchy of suprasystem and subsystem functions; 3) functions are interrelated and integrated to achieve a purpose; 4) interacts with its environment; 5) requires inputs from its environment; and 6) has complex problems each with multiple factors.

*Reproduced with permission from the *Asian Journal of Communication*, AMIC, Singapore.

Problematique analysis puts emphasis on the accurate description of interrelationships of factors or problem symptoms and causes as identified and felt by the informants, as determined by the evaluator from the analyses of records and documents, and as observed from natural setting. Few tests so far have been conducted, employing problematique analysis in the Philippines, practical lessons have been learned. These lessons, hopefully, will lead to better application of problematique analysis as a means of understanding the problem structures of communication systems.

Introduction

The concept of problematique analysis is based on general systems theory and has been applied in other fields such as business management. The concept can be traced to the term problemistic search which is the search that is stimulated by a problem and directed toward finding a solution to that problem (Thompson, 1967). Problemistic search was first introduced by Cyert and March (1963) in connection with their research on organizational decision-making. Problemistic search reflects concepts of causality which are predominant in complex organizations.

The essential idea of problemistic search was adopted by Tiffin (1978) who developed a methodology that enabled him to identify the “root causes” of the problems of instructional television in Latin America. Tiffin called his methodology problem structure analysis. He emphasized that with this methodology, he was searching for problems rather than solutions.

Analyzing the concept of problemistic search or problem structure analysis from the point of view of educational technology, Molenda (1978) suggested that there lies a whole network of problems which does not have an English term in the field of educational technology. He offered a French term “problematique” as a label for the conglomeration of interconnected dissonant elements.

Problematique analysis is based on the systems assumption that “problems within human systems are seldom multiple and unitary. That is, we usually find clusters of multiple problems themselves having multiple causes” (Molenda and DiPaolo, 1979, p. 52). These clusters of multiple problems in human systems are obviously interrelated, and therefore, must be solved as a whole. Dealing with the problems one by one and independently will not solve the problem, and may, in fact, add to the problematique. As Molenda (1978) pointed out, often, “if one tries to solve individual problems one-at-a-time, he/she discovers that the solutions in turn generate problems of another class, only adding to the problematique” (p. 3)

Molenda’s conceptualization of the problematique gets support from Tiffin’s research. What initially appears to be a single problem, Tiffin observed, may prove upon analysis to consist of many problems. Problematique analysis enables one to view the problems of media systems holistically. This is important because media problems must be seen and examined in their full complexity if there is to be any real chance of solving them.

According to Molenda (1978), the basic assumptions of problematique analysis are:

1. a media system is purposive;
2. a media system exists in a hierarchy of suprasystems and subsystems of critical functions;
3. the functions of media systems are interrelated and integrated to form a unitary system to achieve a purposes;
4. a media system interacts with its environment;
5. a media system requires inputs from its environment to function; and
6. a media system has complex problems, each of which has multiple influential factors.

Basic procedure

To better understand the language of media organization management, Campbell (1975) suggested a process of analysis consisting of five steps. These steps are 1) identify the whole; 2) separate the whole into its parts; 3) identify each part; 4) show the relation of each part to each other; and 5) limit the process to the point where further division would destroy the identity of the part.

This procedure closely resembles the first two of four steps in problematique analysis discussed orally by Molenda in a research symposium in 1980 in Indiana University. He recommended that the following steps be adopted:

1. define the boundaries of the system of interest;
2. define the critical functions that ought to exist in the media system;
3. gather evidence; and
4. determine whether or not the critical functions are functioning.

Boundaries of the system of interest

Describe the formal organization structure of the media system showing the system's linkages with other systems and in relation to a suprasystem. For example, in the case of an instructional media programme in a university, the boundaries would include the formal organizational structure of the instructional media programme and its linkages with other systems within the university and in relation to the over-all organizational structure at the university (suprasystem).

Critical functions

Determine the critical functions that ought to exist in the media system. This process may include describing both the formal and informal structure of the media system, as well as identifying personnel roles and relationships. The critical functions are those which, if not present or operational, will prevent the system from operating efficiently and effectively.

Gathering evidence

Gather information through interviews, observations, and analysis of records and documents. This is a naturalistic inquiry approach.

Status of the critical functions

Describe the status of the critical functions. The description may include information on personnel, kinds of activities, amount of work, availability of materials, and other information relevant to the operations of the critical functions. Then draw problematique maps to help explain the status quo of the critical functions.

The problematique maps are used to illustrate the factors that influence the efficient functioning of the critical functions. A hypothetical problematique map is shown in Figure 1.

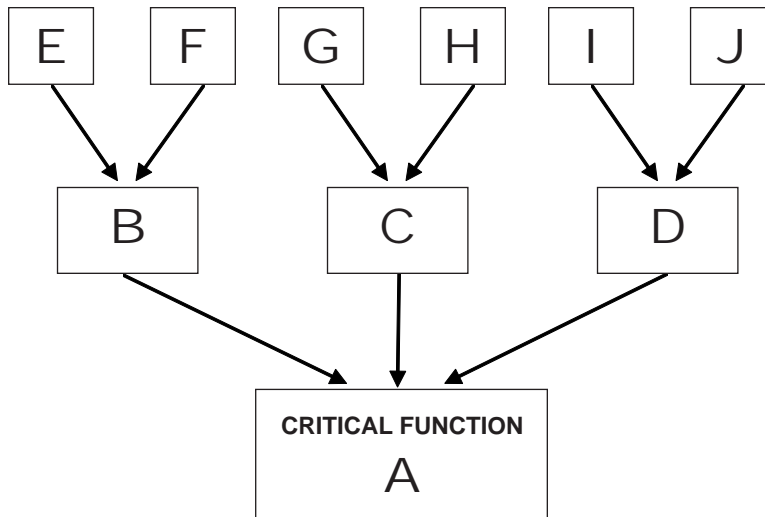

Figure 1. Hypothetical problem structure map

Gathering Information

Sources of information

Possible sources of information necessary in the conduct of problematique analysis include: personnel sources, records and documents, and existing facilities.

Personnel sources. Respondents should include all the knowledgeable persons in the media organizations. That is, personnel involved in the different critical functions should be interviewed, e.g., media managers, planners, evaluators, designers, producers, trainers, distribution staff, maintenance staff, and media users.

Records and documents. The media organization should have a complete file of records and documents regarding its inputs, outputs, and operations. These should be analyzed in relation to information obtained from other sources.

Existing facilities. The information to be obtained from existing facilities is based on ocular observations of the facilities. It is necessary to observe or inspect personally what facilities and equipment are available.

Research instrument

To answer the fundamental questions regarding the media system, an interview schedule would be necessary. A master interview schedule which contains schedules representing the critical functions should be drawn up. Questions from the respective subschedules are used in interviewing key informants in their area. For example, media managers should be asked questions on the management's critical function, and designers should be asked questions on the design critical function. Therefore, questions would deal with each of these critical functions: management, planning, design, production, distribution, utilization, training, maintenance, and evaluation.

Collecting information

To obtain information from the respondents, the researcher should interview each one. When a question from the interview schedule uncovers an influential factor, the question "what do you think influenced this factor?" is asked. If the answer still indicates another influential factor, the same question is asked until:

1. a superordinate influential factor is identified;
2. the influential factor is traced to another critical function;

3. the influential factor is traced to a problem outside of the media system; or
4. the influential factor loops back to a pre-established influential factor or problem

This procedure will entail an interview time of at least one hour for each informant. After each interview, the interviewer should take time to code and categorize the answers that identify the problems and influential factors.

Information gained from the three sources might substantiate and/or cross-check one another. It is understood, however, that it is possible that an answer to a question might be obtained only from one informant or one source.

All the essential questions should be included in the master interview schedule. Some subschedules may be used to interview some respondents depending on their orientations. On the other hand, some questions may be answered by inspecting facilities or analyzing records and documents rather than by interviewing.

Analyzing the Information

Description of the media system

This description includes the analysis of the formal organizational structure of the suprasystem, with the analysis showing the relative position of the media organization or system under study. In the same vein, the media system should be described in terms of the formal organizational structure, as well as its informal social structure. This includes the identification and definition of the problems and influential factors in the media system. This can be achieved by describing the status quo of the critical functions of the media system.

Problematique maps

The second stage of the information analysis will deal with the construction and analysis of problematique maps. A description of the relationships of influential factors in each of the critical functions is the basis for constructing the problematique maps for each critical function. This way, the influential factors can be clearly identified. The problematique maps will show causal and hierarchical relationships of the influential factors.

Pioneering studies

Using problem structure analysis or problematique analysis, Tiffin (1978) sought to identify the problems of instructional television (ITV) in Latin America by studying eight ITV systems representing 50 percent of the ITV systems in that region. To gather information, Tiffin developed a set of questionnaires, one for each of the critical subsystems (critical functions). The fundamental questions Tiffin asked were:

1. does each of the critical subsystems (critical functions) exist?
2. do they function?
3. are their outputs satisfactory to the system they serve?
4. what are the problems?

For each problem discovered, the respondent was asked: what caused this problem? If the answer indicated yet another problem, the same question was asked again until:

1. a root cause (superordinate influential factor) was discovered;
2. the cause (influential factor) was traced to another critical subsystem (critical function);

3. the cause (influential factor) was traced to a problem outside of the ITV system; or
4. the cause (influential factor) looped back to a pre-established problem.

Of the 17 critical subsystems (critical functions) in the ITV system as identified by Tiffin, three were classified as control subsystems (evaluation, planning and decider or management, and the rest as process subsystems, e.g., production, utilization, and so forth). The results of the study indicated that links between control subsystems were interlocked. That is, the problems of the decider subsystem were to some extent due to the problems in evaluation and planning (Figure 2).

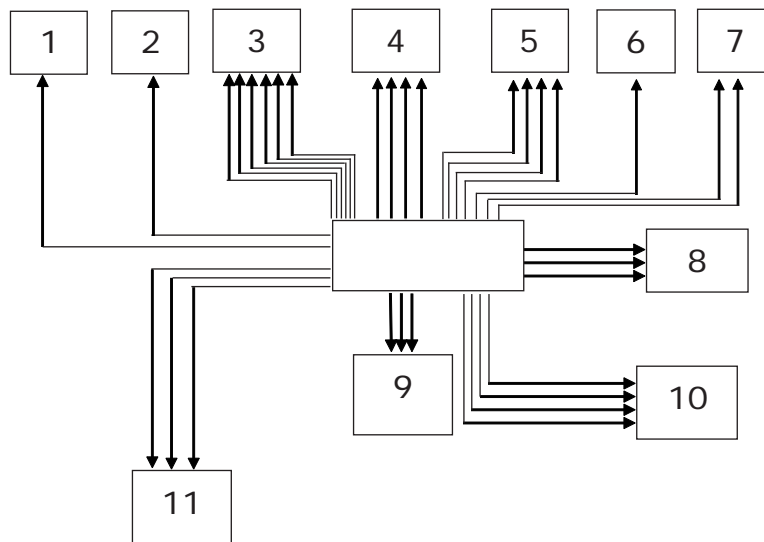

- | | | |
|-------------------------------------|-----------------------------|---------------------------|
| 1. Poor relations among Ministries | 5. Will to impose TV | 9. Problems of planning |
| 2. University administration | 6. Problems of Telemaestros | 10. Decider not internal |
| 3. No consideration of alternatives | 7. Evaluation ignored | 11. Problem of evaluation |
| 4. No needs analysis | 8. Lack of competence | |

Figure 2. Causative links for problems of decider
(Tiffin, 1979, p. 215)

Tiffin said of his findings:

1. Problems in process subsystems were primarily linked to problems that were internal to the system;
2. Problems in control subsystems were primarily linked to causes external of the ITV system.

The basic weakness of Tiffin's analysis is that the relationships of influential factors were not indicated. What he did was to establish a definite linkage between the subsystem and the influential factor. This means that one cannot use Tiffin's method of analysis as basis for determining the hierarchical interrelationships among the factors. The strength, however, is that the problem structure map clearly indicates the magnitude of the influential factor as represented by the number of lines interconnecting the factors and the subsystems.

In the study conducted by Molenda and DiPaolo (1979), they found a network of influential factors operating in each of the critical functions of the Audiovisual General Department, Ministry of Education of Egypt. Through interviews, observations and analysis of records and documents, the researchers identified causal and hierarchical relationships between influential factors. In attempting to make sense out of the problem networks they discovered, Molenda and DiPaolo constructed problematique maps indicating the hierarchical arrangements of the subordinate and superordinate factors and their relationship to the overall critical function problem. For example, problematique of the management critical function is presented graphically in Figure 3.

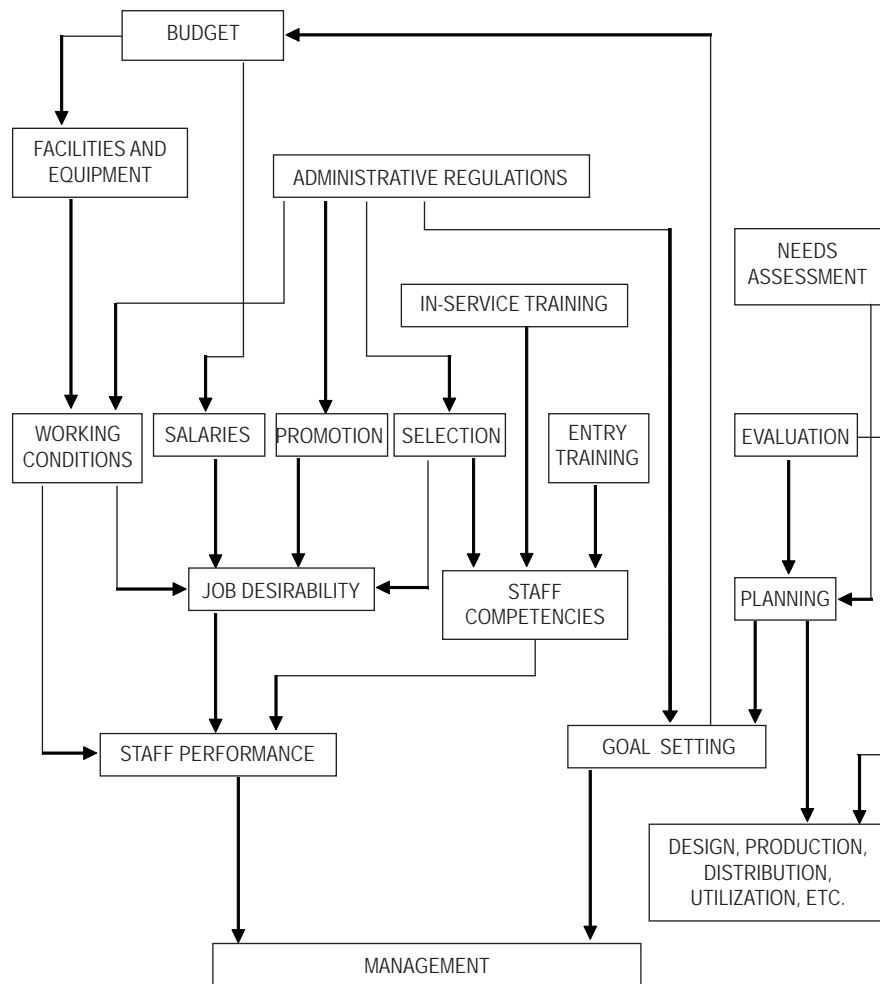

Figure 3. Problematique map of the management critical function, Audiovisual General Department, Ministry of Education, Egypt (Molenda and DiPaolo, 1979, p. 76)

As shown in Figure 3, the critical function management is affected by a number of hierarchically-related influential factors. The factors highlighted in the problematique map may differ in their magnitude as suggested by the number of subordinate influential factors that they influence. For example, administrative regulations directly influence four subordinate influential factors, while budget directly influences three subordinate influential factors. However, goal setting influences budget planning. Put in another way, the arrows indicate the magnitude of the problem that originates from the unsatisfactory condition of the superordinate influential factors. All of the influential factors identified in Figure 3 have direct or indirect negative influence over the critical function management. The influential factors, which may have positive effects, are not indicated considering that Figure 3 is a problematique map.

It must be borne in mind that the choice of which critical function to highlight in a problematique map is arbitrary. Furthermore, the influential factors within a problematique map may also include other critical functions operating as influential factors, such as in the case of planning.

Studies in the Philippines

In the Philippines, some studies have been conducted utilizing problematique analysis. These studies involved media organizations and other communication systems in general.

Puyaoan and Sy (1982) analyzed the problem structure of GMA-7 (a television station in Manila). They collected their data following the data collection procedure adopted by Tiffin (1978) and Molenda and DiPaolo (1978). One of the critical functions or subsystems of GMA-7 that they analyzed was the TV station's Programming and Operation Division. They uncovered at least 12 factors involved in the problem structure of the division.

As the problematique map (Figure 4) indicates, the two factors that strictly affect programming and operations at GMA-7 are staff performance and sales. These two are in turn affected by 10 other factors. However, the root cause seems to be traceable to the budget of the Division, but the budget is also directly affected by sales or advertising revenues and the use of expensive foreign films.

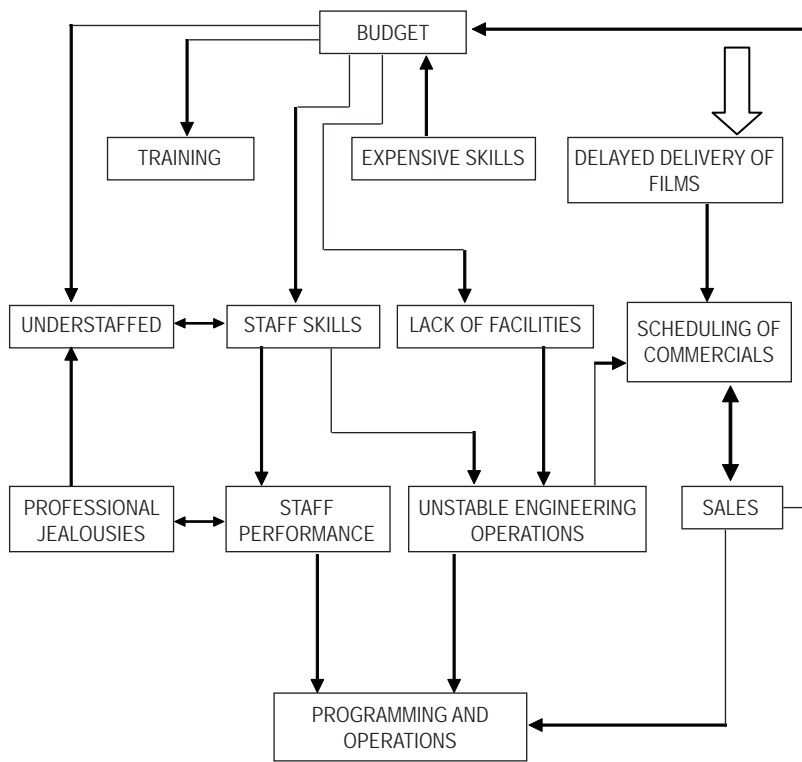

Figure 4. *Problematique map of the Programming and Operations Division of GMA-7 (Puyaoan, Sy, and Librero, 1982, p.23)*

In the study of the management critical function of Radio Station DZLB of the University of the Philippines at Los Baños conducted by Flor (1982), he was able to establish 18 factors that influenced the management of the radio station. The problematique structure map (Figure 5) constructed by Flor was more complicated than what was generally known by the administrators of the radio station.

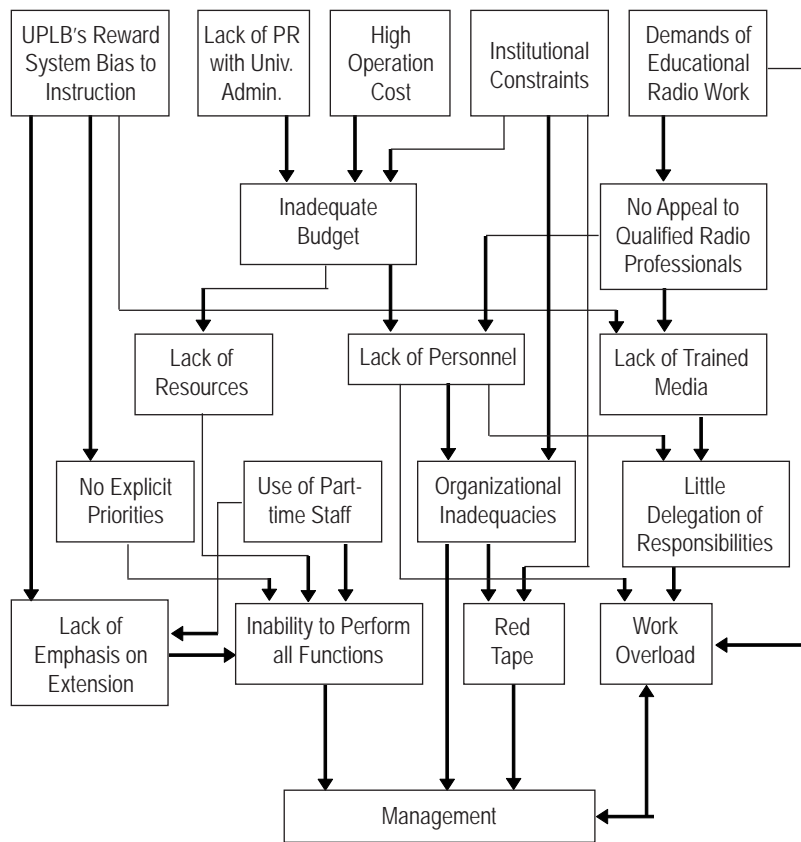

Figure 5. Problematique map of the management critical function of Radio DZLB (Flor, 1982, p.74)

At that time of Flor's study, four factors directly affected DZLB's management. These were:

1. Inability to perform effectively all the functions of research, instruction, and extension at the same time;
2. Organizational inadequacies;
3. Red tape; and
4. Work overload.

When the researcher traced the interrelationships of the 18 influential factors, he identified five root causes, which were:

1. UPLB's reward system bias against the nature of DZLB's operations;
2. Lack of effective public relations;
3. High cost of operations;
4. Institutional constraints; and
5. Demand of educational radio work.

Two of these root causes were identified to be externally controlled (UPLB's reward system bias and institutional constraints). This means that even if DZLB was able to do something to improve its public relations efforts, reduce operational costs, and defuse the work overload, the problematique would probably still remain given that the two externally controlled influential factors would still be able to create a situation wherein the symptomatic factors would still remain.

In both studies cited, the problematique map also clearly showed the influential factors that were externally controlled. That is, the factors that the system cannot do anything about. For example, in GMA-7 study, the externally controlled factor is the delay in film deliveries from abroad. This is critical because the programming of GMA-7 at the time of the study, to a large extent, depended upon canned foreign programmes. In the case of the DZLN

system, however, one of the two major factors controlled outside of the DZLB system is UPLB's reward system bias. The reward system at UPLB is biased towards higher academic degrees and instruction so DZLB could not hire competent and experienced radio personnel at competitive salaries. The other major factor is institutional constraints, or the unique situation of the radio station. It is a small unit of a public academic institution whose priorities differ from those commercial media organizations.

In a later study, Librero (1984) looked more closely at a more extensive communication system – that of the Department of Agriculture of the Philippine Government. The specific units studied were seven regional communication subsystems.

The study revealed a total of 45 influential factors affecting directly or indirectly the operations of the regional communication subsystems of the Department of Agriculture. Of these, 17 were those mentioned at least twice by the informants. For practical purposes, only those mentioned at least twice were included in the construction of a composite problematique map (Figure 6).

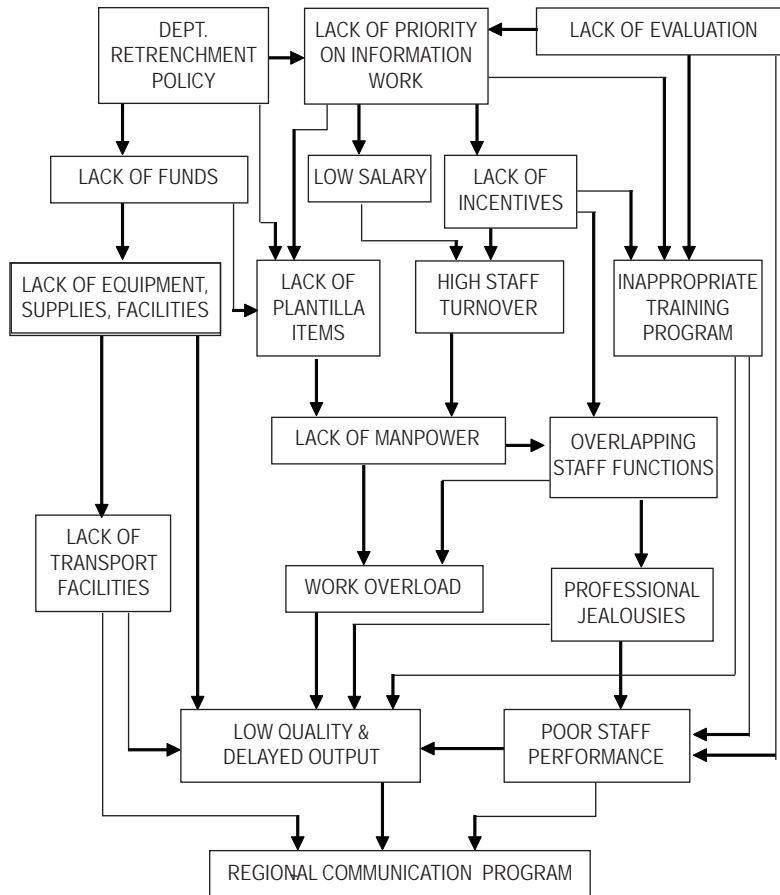

Figure 6. Composite problematique map, Department of Agriculture, Regional Communication Programme, Philippines (Librero, 1984, p.6)

As shown in Figure 6, there are three factors that are directly related to an inefficient communication subsystem. These are:

1. Lack of transportation facilities;
2. Unsatisfactory quality and delayed output; and
3. Poor staff performance.

Three factors were identified as the root causes ultimately resulting in an inefficient regional communication subsystem. These are:

1. Government retrenchment policy, which spawned other problems;
2. Lack of priority to information work as indicated by lack of resources and logistical support provided for information work; and
3. Lack of evaluation of the information work being done by the regional subsystems.

The studies reviewed here show that problematique analysis is a workable methodology for analyzing communication systems. The problems of communication may not always be quantifiable, and these unquantifiable pieces of information may explain why communication breaks down or why communication programmes fail. However, in doing a problematique analysis of communication systems, certain pieces of information may have to be expressed in quantified terms. In other words, the combination of quantitative and qualitative analysis may contribute more to the explanation and understanding of problems of communication systems.

Some Lessons Learned

There are four general lessons learned from the studies reported insofar as the application of problematique analysis is concerned. Along with these lessons are four suggested precautions to ensure that one would apply appropriately the technique of problematique analysis. These lessons learned are:

1. It is very easy for a researcher, particularly an inexperienced one, to rely heavily on his/her own perception and judgment of the relative importance of a particular influential factor specially when the

influential factor is merely implied rather than explicitly expressed by informants. Given that the procedures do not completely lend themselves to statistical testing, it is quite difficult to determine which influential factor would be considered more important in the hierarchical relationships. It would, however, be helpful if all relationships could be expressed in terms of some statistical values so that their magnitudes may be established to some degree of accuracy.

2. Very often, it is extremely difficult to obtain important information, particularly if such information is classified. Experience has taught us that even unclassified or declassified information is often difficult to obtain. In this regard, information sources may purposely provide inaccurate and confusing sets of data. Inaccurate and/or confusing data can lead to a totally different and confusing visualization of the structure of the problems of the communication system. Any decision based on this kind of problematique map can conceivably result in major blunders in the communication system.
3. Problematique analysis is capable of showing clearly the symptoms and root causes of problems in the system. By constructing the hierarchical relationships of influential factors involved, one will ultimately be able to show the root causes of the problem. This shows the decision maker the appropriate decision point. This is important because we frequently apply solutions to what we think might be the causes of the problem, but these may really be the symptoms of the problem rather than the root causes. It is no wonder that when this happens, problems always resurface.
4. It is much easier for the decision-maker to understand and interpret the interactive nature of influential factors when these are presented in the form of problem structure maps than when they are presented merely

in statistical tables of relationships. The decision-maker who is weak in interpreting sophisticated and complicated statistical information such as unfamiliar indices will find the graphic presentation easier to understand and interpret. The significance of this is that decision-makers normally require simplified sets of information so that they can make the necessary decisions right away. Problematique analysis provides the simplified sets of information that the decision-maker can easily act on at any time. The problematique map even shows where the problem and the causes are located.

On the basis of these lessons extracted from research findings, the following precautionary measures are suggested to ensure appropriate application of problematique analysis:

1. Problematique analysis should be more helpful and useful to the experienced researcher than it would be for the inexperienced one. In other words, naturalistic or qualitative research is handled much better by researchers who have had experiences doing both quantitative and qualitative researches.
2. The researcher employing problematique analysis must have a mastery of various means of information gathering techniques. One with the ability to extract critical information through skillful probing and putting the responses of information in their proper perspective would be more successful in using problematique analysis than one who is unable to think quickly of follow-up questions to probe into the subject matter of an interview.
3. Assuming that those various types of information that are very important in the study of the communication system are not always available easily, one has to employ other techniques of getting the information.

Investigative techniques need to be employed in the search for information to be used in problematique analysis.

4. In trying to understand the problems of the communication system, the evaluator must always ask a question, bearing in mind that such questions are only a tiny part of the entire whole. Therefore, all information must be viewed from the system level because the information by itself may not mean much, but when related to other pieces of information in other parts of the system, such information may turn out to be critical in understanding the entire problematique of the communication system.

References

- Campbell, James C. (1975). Some words about organizations. In S.D. Zalotimo and P.J. Sleeman (Eds.), *A systems approach to learning environments*. Roselle, NJ: MEDED Projects, Inc. pp. 301-311.
- Cyert, R.M. and J.G. March. (1963). *A behavioral theory of the firm*. Englewood Cliffs, NJ: Prentice-Hall, Inc.
- Flor, Alexander G. (1982). Problem structure and cost analyses of a rural educational broadcasting station. Unpublished M.S. Thesis. University of the Philippines Los Baños.
- Librero, Felix. (1985). Problematique analysis: a methodology for evaluating communication systems. Inaugural professorial lecture as Ayala Assistant Professor of development Communication, University of the Philippines Los Baños, 17 June.
- Librero, Felix. (1984). Problem structure analysis of the national communication system of the Ministries of Agriculture and Natural Resources. *Devcom Quarterly* (April-June), 11(2):1-14.

- Molenda, Michael H. (1978). Educational technology and the "problematique of higher education." Bloomington, Indiana (June). Typewritten.
- Molenda, Michael H. and Anthony DiPaolo. (1979). An analysis of problems and possibilities of the Audiovisual General Department. A report prepared for the USAID/Cairo. 18 June.
- Puyaoan, Rodelia B.; Lourdes V. Sy; and Felix Librero. (1982). Management problems of television. *Research at Los Baños* (October), 1(3):20-25.
- Thompson, James D. (1967). *Organizations in action*. New York: McGraw-Hill Book Company.
- Tiffin, John W. (1978). Problems in instructional television in Latin America. *Revista de Tecnologia Educativa* IV (2):183-235.



Appendix E

Getting Published in Academic Journals: Some Practical Guidelines

By

Felix Librero, PhD

*Professor of Development Communication
U.P. Open University*

Introduction

When Dean Teresita de Villa of the Faculty of Education, U.P. Open University, requested me to give this talk earlier this year, the topic that was given was “International Peer Review Process and Publication of E-Journals.” These are two distinct topics because the peer review process and publishing electronic journals are two different things. To give justice to the topic,

Lecture outline for the Southern Tagalog Regional Research Conference, Commission on Higher Education, Region IV-A, Lipa City, September 2011. The Conference did not push through, but the paper is reproduced here.

however, I took the liberty of refocusing the presentation in such a way as to enable me to touch on both issues in one session. The resultant focus, therefore, is actually a story with long and winding turns, as intimated in the first line of the song, *He Ain't Heavy, He's My Brother*, popularized separately by the Hollies and Neil Diamond in the sixties.

A bit round about, too, I'd say, because the story includes why we should or couldn't publish, why we should publish our work, how to write publishable journal articles, a few words about the issue of plagiarism, which is becoming a problem of pandemic proportions today, going through the peer review process, and finally what we mean by the electronic journal.

To academics, getting published is a very important achievement. Going through the process is daunting, yet most of us still brave it. Let me explain three reasons most academics would want to go through this frequently humbling experience: why you want to get published, why you are not able to publish, and why you need to publish your work.

Why Do You Want to Get Published?

There are both philosophical and practical reasons why we want to get published. Regarding the philosophical reasons, author Abby Day (1996), a British educator and author of *How to Get Research Published in Journals*, said there are four good reasons to publish your work. First, she says, "because you have to." Many academics do have the propensity to publish not by choice but by demand of their profession. To some degree, it has become an obligation.

Another reason Day cited is “because you want to get ahead.” In today’s world, those who are very good in communicating with their peers are definitely in demand. For academics and most professionals, this happens through publications.

Third reason cited by Day is “because you need to learn from others.” This happens when you get feedback from other experts in your discipline about your publication. Feedback frequently leads to collaborative work, particularly in the publishing process. This refers to the top three types of feedback specially from referees or reviewers: your article may have been accepted, rejected, or sent back for revision.

Sometimes we are dismayed and discouraged when we get rejection letters from journal editors. Personally, I don’t get discouraged by rejection letters, of which I have received quite a number. I just look at the experience as a learning experience. When your article is rejected for publication in a particular journal, there are very important reasons for such rejection, which are normally described in the letter that you get from the editor. So learn from the experience.

A fourth reason why you should publish, according to Day, is “because you need clarity.” What does she mean by this? This refers to writing with a focus because no one can write without a focus. When you write, you are able to clarify your thinking by putting difficult and usually abstract concepts into words that others may understand better. When we write, we try to write, then edit what we have written, then we revise, and actually do everything possible to make what we have written (our argument) much clearer and better understood.

Perhaps one of the many time-tested measures of successful membership in the academic community is academic publications, hence the traditional “publish or perish” syndrome. It is a compelling reason to publish, indeed. For

example, we at the U. P. Open University must publish if we want to be promoted. In fact, one of the requirements for tenure is at least one publication in a peer-reviewed academic journal.

When I was Chancellor of the UPOU, we had to let go of five very good Assistant Professors because they lacked the publication requirement to remain on the teaching staff of the university or to get promoted to the next rank. We did not renew their appointments even if we needed them badly during the incoming semester. These were people we had trained in the last three years to do the things we had promised we would do as an open university. They were, of course gladly recruited by other institutions that intended to offer courses online. They are now happy in their new jobs as they're not required to publish, and they're getting much better salaries, too.

At the UP Open University, when one crosses the rank of assistant professor to associate professor, one must have published two articles in a refereed journal during the time that she/he has been assistant professor; and from associate professor to full professor, three publications. Any promotion within the rank requires at least one publication for each promotion within the rank. All these, of course, are on top of other usual requirements like high teaching evaluation rates, extension involvement, creative work involvement, and the like.

Why You're Not Getting Published

Now, the question is, why are you not published? Day (1996) also names four reasons why people don't get published. You may have heard of these reasons before, but what exactly do they mean? Let me call these four as syndromes.

First, the *not-good-enough-yet syndrome*. I know of many academics, including Filipino academics, who do not have publications, or have not published thus far, because they don't like to publish what they consider "mediocre" articles. They want their articles to be perfect when they are published. Well, there's no such thing as a perfect article.

According to Day, the central issue is what she calls "going public," which is a phenomenon derived from the Latin word *publicare*, or to make public. Getting published, of course, has its advantages and disadvantages. When you get published, expect criticisms even as you may receive congratulatory remarks. I have always believed that Filipino academics don't publish because they don't like to be criticized for what they have said, but they are generous with their own criticisms of someone else's work.

If you have a research, you publish it for a basic purpose: to gain feedback from other experts so that you might improve your work. If you are scared that other experts might think you did a lousy job of it, then you'll not get published and your ideas will remain unknown. Down the road, someone who may not be scared of being criticized will eventually publish a similar paper. You may find that paper worse than what you wrote earlier, but the other person got published and you did not. In the following years, various researchers, experts, and authors will publish articles related to the original idea until it becomes acceptable hypothesis, or principle, or theory that shall have been accepted by the scientific community. Then, you'll regret not having published it first.

Second, the *fear-of-rejection syndrome*. Many academics simply are afraid that when they submit an article for publication, the journal will reject it. I have received quite a number of rejection letters myself and I can tell you that I did not like the idea of being rejected. No one does because rejection is taken to mean failure. Therefore, the more you

don't like receiving rejection letters from journals, the more you'll not submit any paper for publication, and the more you will not get published.

If, in spite of getting rejection letters now and then you continue sending out articles for publication in journals, the likelihood of getting published becomes higher. That, of course, means you'll have to maintain some form of standards of quality in your papers. In doing so, you'll have to focus on what Day (1996) refers to as success factors, namely: proper identification of your target audience, clear purpose of why you are publishing your article, and clear statement of the implication of your conclusions in the article.

Third, *people-might-steal-my-idea syndrome*. You shouldn't be afraid of people using your ideas. According to Day, "if your work is original it can't be replicated easily," if your methodology is rigorous it can be replicated very easily, and if you have argued well that your work is important, then it can stand as an original piece of work. It is not enough to simply have a good idea, although that is an extremely good start.

Day (1996) cited the respected British scientist, Sir Douglas Hague, as having said: "The whole point of academic research, of course, is that its findings should not be opaque and inaccessible, but available to those who could benefit from them - not least those outside universities."

This is precisely the reason by academics who are well-published rarely fear that their ideas will be stolen by others because they do understand that mere ideas are cheap and that no one really gets anywhere simply because he/she thought of something. If you want your ideas to be useful to you, then you must be able to communicate them clearly to others.

Fourth, *I-don't-have-time syndrome*. Of course, you'll never have enough time. Sometimes I call this the "graduate student syndrome." You'll always be busy with something, usually mostly insignificant things. Management experts who study use of time seem to agree that the people who use their time wisely are usually those who are able to concentrate intensely on whatever it is that they are doing. Well-published authors are probably as busy as or perhaps busier than you are, but they are able to manage their time wisely. It's not a question of how much time you have, but how most effectively you make use of such time. In other words, time is not the problem.

Publishing-Mad World

We live in a publishing-mad world. The amount of publications has been taken to reflect the amount of new knowledge discovered by scientists. About five decades ago, the scientific knowledge was growing exponentially, according to Price (1963). He observed that "if any sufficiently large segment of science is measured in any reasonable way, the normal mode of growth is exponential." This meant that the size of scientific knowledge was doubling every 15 years. This increase in new knowledge has always been measured in terms of increase in the number of academic publications and was found to be increasing by a factor of 10 every 50 years (Martin, 1981). In the year 2000, therefore, there were supposed to be 1,000,000 academic journals in the world. The online journals are not included in this count. By year 2050, there will be 10,000,000 academic journals in the world. Again this does not include online journals and books. Martin (1981) estimated three decades ago that there would be 200 million book titles in the year 2040. It's a good thing that these books are now digitized so there is much less problem of space where they could be stored. Otherwise, with 200 million books, stored in the traditional fashion, a library would require something

like 8,000 kilometers of bookshelves and a card catalog of 750,000 drawers.

The appropriate question now is, do we still have an opportunity to publish original work today, given that practically everything has been studied? This is not only a common question but a legitimate one as well. Given all the publications left and right, one wonders if we would still be able to come up with original work that is publishable – a very legitimate concern, indeed. However, if you look carefully at the scientific literature of your discipline, you'll see that much of what is there would be reports of application of theories or part of theories applied in specific locales, employing new methods of doing things, and the like. You'll find as well that highly innovative ways of applying or explaining certain theoretical propositions using different data sets are not frequent. Too, you'll realize that at least in the Philippines rarely do you find articles that are actually discussions of innovative analysis of secondary data. These are still considered original work.

Writing a Publishable Journal Article

If you want to write, write! This was the best advice I got from my professor in journalism when I was an undergraduate student. Indeed, you can't become a good writer by simply thinking that you're a good writer. However, even if you may inherently be a very good writer, you'll have to consider certain factors that bear on the quality of your articles. In an online seminar conducted by Dr. Dan Remenyi (<http://www.academic-conferences.org>) he discussed major factors that writers must be fully aware of. Let's look into these factors.

Understanding the different types of articles or papers

In general, you can write quite a number of different publishable articles, but let's consider possibilities just in relation to one completed research project. Here are some articles that you might be able to produce out of one research project report.

Full research report. The most common type of article would be reports on research findings. This article would contain all the aspects of the research project undertaken but treated as a journal article, therefore, it should adopt the format that the journal requires.

Literature reviews. I recall that when I was in graduate school my professor in research methods specifically pointed out: "the most publishable portion of your dissertation is the review of the literature" (based on class lecture of Dr. Ivor K. Davis, Indiana University, 1978). He said that everybody in the discipline would be interested to find out what you did with the literature. Literature reviews are syntheses of the latest in the discipline. The wider your scope of coverage, the more your review will be welcome because it would indicate how much work you have done to be on top of the new developments in your discipline.

Theoretical or speculative discussions. Normally, research projects would have theoretical frameworks, on which the research is anchored. A more detailed and clearer, perhaps innovative, discussion of this theoretical framework will be useful to most readers of the journal. For example, other academics would be glad to know other ways of treating a theoretical proposition. There may be a fresh way of looking at a particular theoretical proposition.

Methodological discussions. New methods of doing things, especially if they can help arrive at new ways of understanding concepts and phenomena are always interesting to academics. Academics are always interested to know the results of innovative approaches such as reconceptualizing or revising traditional methodologies and testing such innovative formulations.

Comments, communication, reviews, critiques. Well-researched critiques or comments on current issues in the scientific community, particularly as regards appropriate application of methodologies or interpretation of data, are always welcome materials for publication. They provide fresh views on otherwise common issues in the scientific world.

Difficulty of getting started as published academic

Not fully seeing and understanding the opportunities. I have had numerous opportunities to discuss with academics, young and old, in various Philippine universities, and have been amazed by the publication productivity of many. But what they write are mostly extension-type materials dealing with subject matters outside their academic disciplines. For example, we have so many academics involved in agricultural programs. These same academics are in an excellent position to undertake disciplinary research under field conditions and learn how their discipline effectively inter-relates with social issues and development programs. Such are rich sources of potential academic journal materials. Perhaps these academics have not had the time to really see the potentials and opportunities before them.

Fear of failure. There are many who do not like to start because of fear of failure. This is a powerful negative motivation. As already mentioned earlier in this paper, this fear of failure includes fear of rejection or getting rejection letters

and fear of criticisms. One aspect that potential authors fear is the peer-review process. By the way, did you know that Filipino reviewers are much more strict compared to their counterparts abroad? Sometimes their comments are very critical and their suggestions difficult to comply with as they may not be well-thought out in the first place.

Lack of commitment to publish. What I hear most of the time are assertions that academics want to publish, but that they do not have the time to do research and write articles. If these colleagues of ours truly mean well, then they would always find ways to write and publish. If you think you don't have time to publish, make time for it. Your time investment in publishing will be rewarding in the end.

Lack of institutional support. In Philippine universities, publications are required, say for promotion of academics, but frequently they're left on their own to have their papers published in journals from other institutions mostly outside the country. Whatever journals we have in this country are frequently looked down upon as mediocre because they have not been able to raise their standards to equal international publications. Besides, these publications frequently do not survive beyond one issue because the funds are not there, and frequently they're not peer-reviewed. This may also be largely due to lack of confidence in these journals by our published colleagues, who prefer to have their articles published in journals abroad.

Avoiding failure factors

According to Remenyi, there are six failure factors that commonly influence the productivity of academics in terms of publications. Let's consider these individually.

Unrealistic expectations or targets. As already mentioned elsewhere in the paper earlier on, many academics want to

publish only the perfect article. Unfortunately, there's no such article. In fact, you publish, say a new methodology, for the purpose of getting other experts to comment on it and contribute to improving it until it becomes generally accepted in the scientific community.

Lack of focus. Sometimes, even when you have something important to write about, you are unable to focus on which part you need to expound on because you want to discuss all you have in your mind. Usually, when you write about everything you have in mind the article would not have any focus, a case of too much too foggy.

You prefer high-risk topic. Unfortunately, such topics also require data that are extremely difficult, if not impossible, to access. Furthermore, some journals would not touch these kinds of topics if they know that they would not be able to sustain interest in these with sufficient and meaningful data and high level analysis.

Lack of theoretical knowledge and methodological skills. An academic weak in theory and in methodology would really have a fundamental problem in writing articles on research that would interest readers who are also experts in their own disciplines. Journals are waiting to receive articles on innovative, perhaps even daring but logical or fresh interpretation of theories, but usually this would require very skilful manipulation of methodology. If one is weak in both, then he/she has a problem.

Inability to know when to stop. This is very common among inexperienced researchers, wanting to break into the world of the published academics. This is what I call the "graduate student syndrome." For example, graduate students, when they search the literature, tend to read as much as they can, taking notes on all topics they read about and using all those notes when they write their thesis chapter on the review of the related literature. Why? Because, having exerted

substantial efforts in reading and taking notes, they have to use the information that they gathered so painstakingly or all these would go to waste. Another example is when the researcher asks more questions than the research problem requires. Too many questions lead to too much data, much of which may have weak links with the main research problems. And because the researcher has spent resources in gathering the data, he/she has to use them one way or the other. The result is that the research report, particularly its “publishable” version lacks focus.

Lack of knowledge of appropriate journals. This is a serious shortcoming of academics wanting get published. It is very important that you study the journals you want to publish in. What writing style do they follow? The APA (American Psychological Association) is usually used in the social sciences, MLA (Modern Languages Association) is used in the Humanities and the Arts, while CBE (Council of Biology Editors), is used in the sciences and mathematics. What format do they follow? What’s their requirement in terms of data presentation and use of diagrams and pictures? Read the “Information for Authors,” which is usually printed in the inside back cover of the journal.

Planning a publishable academic article

Planning an article worth publishing is actually planning a research project from which an article for publication may be based. Generally, it involves selecting an appropriate topic to research, assessing the resources you’ll need in doing the study, doing literature review, selecting your study methodology, collecting evidences or data, analyzing those data using accepted statistical tools, and writing the article or report.

Things You Can't Complain About

Most journals today have a waiting list of several articles per issue, hence the editors may not have the time to immediately take a look at your article so feedback from them may take time. Don't be too impatient.

When your article comes back with feedback, you can be sure that those feedback may already have come from the peer reviewers assigned by the Journal to review your article. Comply with the suggestions right away and revise your article accordingly, then send back the revised article to the Editor.

While your article is being considered for publication by one journal, don't submit the same article to another journal. This is highly unethical and considered taboo in academic publication. What is the sanction? Your article will not be published and you will be black-listed. Word gets around fast among editors and publishers, so even if you submit articles to other journals in the future editors in those journals would already know they should not entertain any submissions from you until such black-listing is lifted. This could take a long time, even until forever, and you wouldn't be able to do anything about it.

A Word About Multiple Authorship

In many published articles, you would find multiple authors. How do you list authors properly? An essay originating from the International Scientific Institute (ISI) Press (<http://www.garfield.library.upenn.edu>) described a book titled *How to Write and Publish a Scientific Paper* authored by Robert A. Day (published in 1978), a well-known author and long-time editor of the *Journal of Bacteriology*. Day's discussion of how to treat multiple authors, according to the ISI Essay, is

worth remembering. It says,

... the first or 'senior' author should be the primary progenitor of the work in question. The name of the leading associate should appear second. The third author should have taken a lesser role in the experiments than the second, and so on. Bob also decries that practice of listing the names of people – laboratory heads, for example – who took no part in the experiments or the original conception of the research. While such a practice may be regarded as good grantsmanship, he writes that it is basically dishonest.

A Look at the Peer Review Concept and Process

What is peer review?

The concept of peer review applies in various circumstances. For our purposes, however, we'll look at peer review as a tool to help improve articles for publication in peer-reviewed academic journals. According to the Chancellor's Doctoral Incentive Program of the California State University, as cited in the Center for Distributed Learning website (<http://teachingcommons.cdl.edu>), peer review refers to the "process of screening submitted proposals or manuscripts, and encourages authors to meet accepted standards of their discipline." It is, in general, the "evaluation of creative work or performance by other people in the same field in order to maintain or enhance the quality of the work or performance in that field" (<http://www.linfo.org>). The idea behind the peer review is that a larger group of individuals will be able to detect some weaknesses and perhaps errors in a work or performance and will be able to offer impartial evaluation of said work or performance.

In the case specifically of peer-reviewed academic journals, the peer review process occurs prior to and after publication of an article. Why should peer review still happen after the publication of an article? Frequently, in the academe, evaluation and discussion of ideas even after publication normally continues for a long time until most if not all issues concerned are largely resolved by members of the scientific community, particularly of members of the same discipline.

Why is peer review important?

Peer reviews are designed to “prevent dissemination of irrelevant findings, unwarranted claims, unacceptable interpretations, and personal views” (<http://teachingcommons.cdl.edu>). Consequently, articles not peer-reviewed, if they get published at all, are usually “regarded with skepticism” by members of the profession and scientific community. Corrollarily, therefore, the peer review is not only a process of vetting new ideas but also a process to “improve the prestige and importance of an idea or process” because when they have gone through the peer review process they’re considered to be reliable as their facts and premises have been checked for accuracy (Hinckley, eHow.com). The eHow website (<http://www.ehow.com>) lists the following advantages of the peer review: it helps maintain standards for the discipline, it provides credibility, and it helps improve quality.

Types of peer review

According to Elsevier, a known international academic publisher (<http://www.elsevier.com>) in Europe, there are three types of peer review, as follows:

Single blind review, refers to the situation where the names of the reviewers are not known by the author. This is the

traditional peer review process and by far, the most common type in practice. The singular advantage of this type is that the author cannot influence the reviewer. The problem is that if the reviewer is in the same discipline and possibly in the same university as the author, the reviewer might withhold his comments thereby delaying the publication of the article and giving the reviewer a chance to publish first. It is always a concern for authors that some might steal their ideas through the review process, which, indeed, is a legitimate concern. After all, in academic publishing there's always cut-throat competition.

Double blind review, refers to the situation where both the author and the reviewers are not known to each other, that is, the author does not know who the reviewers are and the reviewers do not know who the author is. The advantage of this process is that if the reviewers do not know who they are reviewing they may not be influenced by the prestige of the author but only by the contents of the article being reviewed. However, experts also say that it is quite impossible not to know who may be the author of a particular article since the world of academic publication is a small world filled with experts and authors who usually know one another. In other words, there's no absolute anonymity.

Open review refers to a situation where all the reviewers and the author or authors know one another, and the process of giving comments and suggestion is open to all. There are other experts who see this process as disadvantageous because it could be less honest where fear of retribution (or vengeance) may influence some to tone down their comments and criticisms. This could be a problem where junior reviewers would withhold otherwise significant comments on the works of their senior counterparts for fear that this would damage their prospects in future publications. After all, those they review will eventually be their reviewers and academic authors may not easily forget and forgive those who made it difficult for them to publish.

What are the pitfalls of the peer review?

The peer review as a practice is not fool proof. In fact, it's not even an assurance that an article will be absolutely devoid of inaccuracies once it gets through the peer review process. An example is an obscure experiment that proponents of the peer review process would rather forget than remember. The website, eHow, an Internet site that focuses attention on the peer-review process, reported what has been known as the Sokal Affair, as follows:

The effectiveness of peer review has been routinely questioned. In 1996, a physics professor at New York University, Alan Sokal, submitted a paper on quantum gravity to a peer-reviewed journal called "Social Text." The paper was nonsensical and sent in as an experiment. As Sokal described it, the experiment was to find if the journal would "publish an article liberally salted with nonsense if (a) it sounded good, and (b) it flattered the editors' ideological preconceptions." After it was published and then revealed to be a hoax, merits of peer review were called into question."

Indeed, serious issues have been raised against peer review, but it has remained a respected part of establishing academic knowledge. The most recent challenge to the peer review process are those posted in the Internet, where most of the documents posted have not had the benefit of testing or confirmation by other experts and disciplinary authorities. This is now the focus of attention in the scientific community.

Until such time that a better method of establishing scientific accuracy is agreed upon in the scientific community, however, the peer review process, with all its infirmities, shall remain a respected process among scientists.

How does the peer review process proceed?

Various journals follow their own procedures. In general, however, the following are the steps of the peer review process (<http://www.jri.ir>):

The author submits an article to the editor of a journal.

The Editor-in-Chief verifies the relevance of the article to the journal's policy. If it's not relevant, he'll return the article to the author with the comment that it is not relevant to the goals of the journal. He might suggest that the author sends it over to another journal. Usually, editors do this to encourage young authors to continue their publishing efforts.

If the Editor-in-Chief finds the article relevant and worth publishing by the journal, he/she identifies reviewers and sends the article to the reviewers for evaluation.

When the reviewers send in their reviews or evaluations, the Editor-in-Chief would usually ask the Editorial Board to study the comments of the reviewers.

Frequently, the author is asked to respond to the comments and suggestions of the peer reviewers.

The author is expected to respond to the comments and suggestions by the peer reviewers as quickly as possible, depending on how soon the author wishes his/her article to get published.

The responses of the author are sent to the reviewers, who determine if the author has substantially clarified the issues that they may have raised. At this point, the Editor-in-Chief may decide to refer the author's clarifications to the reviewer who may have asked the most important

clarification. Usually, this second round of reviews would no longer involve all the original reviewers.

When the peer reviewers have substantially been satisfied with the clarifications of the author, the editors of the journal would approve or disapprove the publication of the article. If they approve of the publication of the article, they would then make some editorial revisions and put the article on the publication line. At this time, the Editor-in-Chief would inform the author that his/her article has been accepted for publication and that the article will appear in a specific future issue of the journal.

General References

- Anonymous. How to write a peer review. Retrieved from http://www.ehow.com/print/how_4471520_write-peer-review.html
- Day, Abby. How to write publishable papers. Retrieved from <http://sigma.poligran.edu.co/politecnico/apoyo/Deciones/curso/howtowriteclean.pdf>
- Derntl, Michael. 2009. Basics of research paper writing and publishing. Retrieved from <http://www.pri.univie.ac.at/derntl/papers/meth-se.pdf>
- Essays of an Information Scientist, Vol. 4, p. 104-108, 1979-80. Retrieved from <http://www.garfield.library.upenn.edu/essays/v4p/104y1070-80.pdf>
- Heathman, Shauna. Peer review writing checklist. Retrieved from http://www.ehow.com/print/list_6709756_peer-review-writing-checklist.html
- Hill, Shawandra and Provost, Foster. The myth of the double-blind review? Author identification using only citations. Retrieved from <http://www.cs.utexas.edu/users.mcinley/notes/hp-sigkdd-2003.pdf>
- Hinckley, Michael. What is peer review? Retrieved from http://www3.ehow.com/print/about_4602242_what_peer_review.html

- How to publish a scholarly paper. Retrieved from <http://literal-minded.wordpress.com/2010/01/13/how-to-publish-a-scholarly-paper/>
- How to write publishable qualitative research.
Retrieved from http://www.parint.org/isajewebsite/bookimages/isoje_2nd_edition_chapter6.pdf
- Joao Pedro de Magalhaes, 2004. Open peer review.
Retrieved from http://jp.senescence.info/thoughts/peer_review.html
- King, Gary. n.d. Publication, publication. Retrieved from <http://Adobe.Reader.10.11.73.222.pdf>
- Librero, Felix. 2011. Plagiarism: an intellectual leprosy. Talk delivered in the 11th Talakayan Series for Environment and Development (TSED), School of Environmental Science and Management (SESAM), UPLB, College, Laguna, 13 January 2011.
- Librero, Felix. 1991. Communication concerns in the scientific community. *The Philippine Agriculturist*, Vol. 74, Number 2, pp. 283-290.
- Peer review definition. Retrieved from http://www.linfo.org/peer_review.html
- Peer review process. Retrieved from <http://www.jri.ir/En/PeerReviewProcess.aspx#>
- Peer review. Retrieved from <http://teachingcommons.cdl.edu/facultyresearch/PeerReview.html>
- Peer review. Retrieved from <http://www.elsevier.com>
- Walton, John. Peer review definition. Retrieved from http://www.ehow.com/print/about_4702830_peer-review-definiion.html
- Wikipedia. Peer review. Retrieved from http://en.wikipedia.org/wiki/Peer_review
- Writing a publishable journal article: a perspective from the other side of the desk. Retrieved from <http://sciencecareers.sciencemag.org>.
- Yargo, John. Importance of peer-review of scholarly journals to a scholarly practitioner. Retrieved from http://www.ehow.com/print/about_6631794_importance-peer-review-scholarly-journalos-scholar-practitioner.html